



 **WEXXAR BEL**®

**WF30T**

**FULLY AUTOMATIC HIGH SPEED**

**TAPE SEALING CASE FORMER**

**EoL**

**END OF  
LINE**

For more information, visit [www.LINCsystems.com](http://www.LINCsystems.com)

# WF30T

FULLY AUTOMATIC HIGH SPEED TAPE SEALING CASE FORMER

## WF30T WEXXAR'S INTUITIVE SMART EXPERIENCE

Wexxar's WISE System provides user-centric features which allows for easy machine operation, maintenance and troubleshooting.

## Precision, Reliable High Speed Tape Case Forming

The WF30T is a top of the line, high speed, fully automatic case former. The use of servo drive motors pushes the machine to unmatched levels of case forming precision, performance, and reliability.

The WF30T features Wexxar Bel's patented Pin & Dome\* system ensures reliable and square case forming throughout the entire process. The machine is in full control of the case at all times, using positive force for all folding functions, ensuring cases are square and easily handling common imperfections found in corrugated boxes.

Servo drive motors also allows for precise and detailed programming for applying different amounts of force when forming the case. This makes the WF30T perfect for high speed applications with lighter or recycled corrugated.



\*US. Patent No 7,766,808 & 7,422,552

### ABOUT WF30T

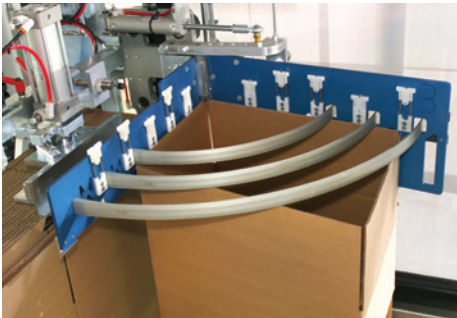

#### RELIABLE AND REPEATABLE PERFORMANCE

Wexxar's patented Pin & Dome technology mechanically captures and positively squares each case with precision and reliability unmatched by any other system.

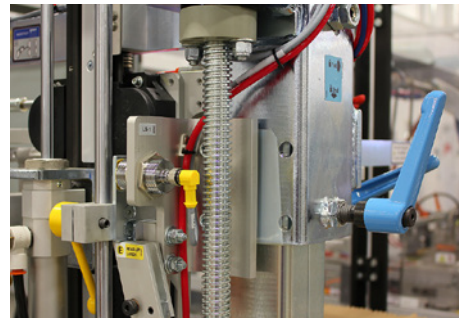

#### EASY MACHINE SETUP AND CASE SIZE CHANGE

User-friendly pictorial guides and tool-less color coded labels and handles for convenient setup and size changes.



#### CONVENIENT TAPE ROLL CHANGE

Minimize downtime with easy accessed bottom tape head for quick size change. (exclusive to Dekka tape head)

### COMPLETE SOLUTION

FULLY AUTOMATE YOUR PACKAGING LINE WITH THESE FORMING AND PACKING SOLUTIONS.



#### BEL 250 CASE SEALER

Heavy duty fully automatic top and bottom tape case sealer provides an effective and reliable solution for high volume 24/7 operation.



#### BEL 290 CASE SEALER

High speed fully automatic top and bottom case sealer provides a safe and effective solution for high volume and high speed operations.

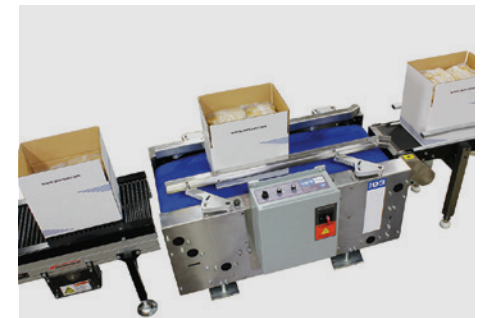

#### WRC CONVEYOR

The WRC case settling conveyor allows for over packing by providing an efficient and effective solution to both transport and settle product simultaneously.

For more information, visit [www.LINCsystems.com](http://www.LINCsystems.com)

## CONFIGURATION

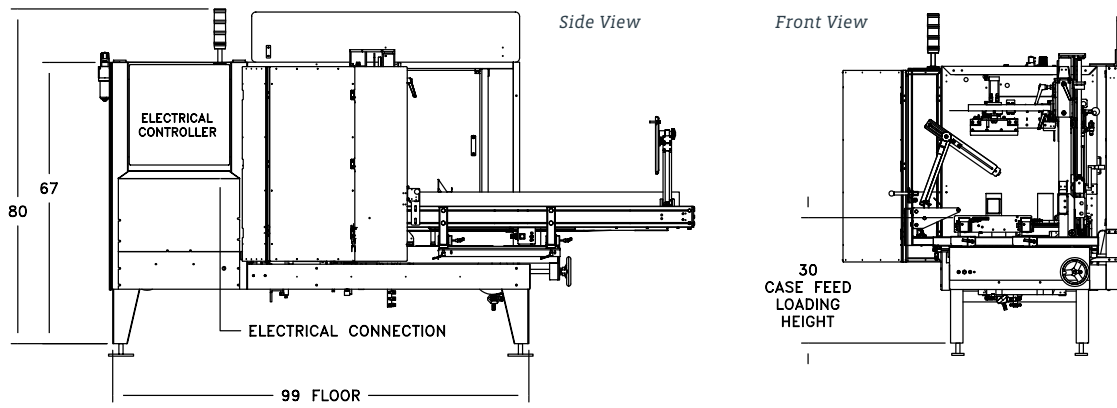

### STANDARD FEATURES

- Pin & Dome case opening technology along with servo drive systems delivers industry leading control and reliability for high speed case forming
- Flex speed along with remote demand provides speed ranges which can be catered to each case size or style
- User-friendly touch screen to control and monitor the machine
- Fully interlocked guard doors allow easy and safe machine access during set-up and maintenance
- Tilt-out tape head for quick and easy tape roll changes
- Tool-less, color coded size changeover in under 7 minutes with user-friendly on machine pictorial guides

### OPTIONAL MODIFICATIONS

- Auto Adjust Package for automatic case size adjustment
- Enhanced Speed Package for up to 30% increase in operation speed

- Surge Control for adaptive case forming speed
- Modifications for undersized or oversized cases
- Enviroguard washdown options available
- Additional guarding packages
- Gap Flap or other case style modifications
- Custom voltages

### OPTIONAL ACCESSORIES

- Machine Management with tri-light beacon for case jam and tape monitoring
- Machine Leg Casters
- Digital Dial Indicators for easy size change
- External Interface Port with power outlet
- Auxiliary Start/Stop/E-Stop Panel

## PRODUCT SPECIFICATIONS

<b>Machine Weight</b>	1500 lbs
<b>Machine Dimensions</b>	156" (L) x 49" (W) x 80" (H) at maximum case size adjustment
<b>Air</b>	20 SCFM; 1.02 cu. ft. per cycle at 90 p.s.i.
<b>Electrical</b>	120 Volts, 1 PH, 60 Hz - 5 amp draw
<b>Speeds</b>	Up to 20 cases per minute

Specifications are subject to change without notice.

\*Expanded range may require tools or change parts. Certain combinations of length, width, and height may require optional modifications. Contact your representative with your exact case specifications.

## CASE SIZE RANGE

Standard Range	LENGTH	WIDTH	HEIGHT
<b>Minimum</b>	7 1/4" 184 mm	7 1/4" 184 mm	6" 150 mm
<b>Maximum</b>	18" 457 mm	14" 356 mm	15" 381 mm

*Under and Oversized model available.*

Expanded Range	LENGTH	WIDTH	HEIGHT
<b>Minimum</b>	6" 150 mm	5" 127 mm	5" 127 mm
<b>Maximum</b>	24" 610 mm	17" 432 mm	16" 407 mm



At Wexxar Bel, corrugated container packaging applications are limited only by the imagination. Our Wexxar case formers and case sealers have been installed in nearly 40 countries and consistently bring customers the lowest cost of ownership and the highest standards of safety. Wexxar also offers the BEL line of corrugated box sealers, tapers, and packing systems as well as the IPAK line of tray and bliss formers, stackers, and sealers systems. As part of the ProMach End of Line business line, Wexxar helps our packaging customers protect and grow the reputation and trust of their consumers. ProMach is performance, and the proof is in every package.



**800.513.9918 | [LINCsystems.com](http://LINCsystems.com)**