

ATH

FULLY AUTOMATIC VERTICAL TRAY FORMER

PERFORMANCE DELIVERED



The IPak ATH fully automatic vertical tray formers are heavy duty machines built for around the clock operation. The vertical design also provides a relatively compact footprint, perfect for operations with limited floor space.

The ATH itself is incredibly versatile, able to form a number of different tray styles from basic 4 corner trays to agricultural trays and more. The machine can also be size-changed over in 10 minutes or less when equipped

with the color-coded Quick Change option. This flexibility allows customers the option of quickly changing into multiple tray sizes or adding future tray sizes.

The ATH is fully loaded with advanced servo technology for fast and accurate tray forming, color HMI touchscreen, and premium build materials. Many options are also available for the machine including an easy loading conveyor system and more.

For more information, visit www.LINCsystems.com

STANDARD FEATURES

- » Self-cleaning Venturi style vacuum picking
- » HMI color touchscreen control
- » Color-Coded quick change with scribed parts
- » Nordson ProBlue hot melt adhesive system
- » Allen-Bradley PLC
- » Fully interlocked safety guarding
- » Digital readouts
- » Textless instructions

MACHINE SPECIFICATIONS

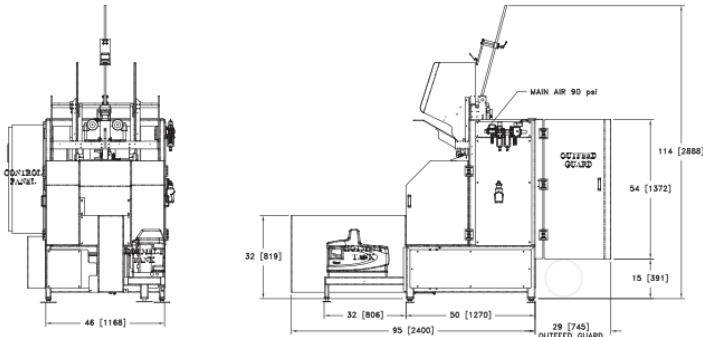

- » Machine Weight: 2,200 lbs
- » Machine Length: (typical) 10'2"
- » Air: (typical) 0.6 cubic feet per cycle at 90 p.s.i.
- » Electrical: 480 Volts, 3 PH, 60 Hz - 16 amp draw
- » Speeds: up to 45 trays per minute
- » NEMA 12 control panel
- » Lock-out / tag-out compliant

THE IPAK PRODUCT LINE INCLUDES:

- » Tray Formers
- » Flange Sealers
- » Case Sealers
- » Stackers
- » Blank Feed Magazines
- » Outfeed Conveyors

OPTIONAL FEATURES

- » Quick Change Package
- » 8' Motor driven out-feed conveyor
- » Machine monitoring system
- » EZ-load Magazine
- » Auxiliary control station
- » External Ethernet and power port on electrical panel
- » Caster kit
- » 4" powered feed magazine

START-UP & TRAINING SUPPORT

- » Complete training with machine orientation, start-up, operation, size and style changeover, and maintenance
- » 24 hour support line (1-888-565-3219)

NEW TRAY INTRODUCTION / RETROFITS

Markets and retailers will from time to time demand changing the size or style of trays being produced. IPak can quickly determine the necessary parameters to accommodate the introduction of a new tray on your existing IPak.

SOME EXAMPLES OF TRAYS FORMED ON THE ATH



4 Corner Tray
with RSC top flap



MUB Tray



Self-lock Tray



4 Corner Tray



4 Corner Tray with
Snap Lock Lid



4 Corner Tray with
One Piece Lid Tuck-in

LINC
SYSTEMS

800.513.9918 | LINCsystems.com

IPAK
MACHINERY

WEXXAR PACKAGING INC.
13471 Vulcan Way,
Richmond, BC, Canada V6V 1K4
Tel (604) 930-9300
Fax (604) 930-9368
www.ipakmachinery.com

powered by **Pro Mach**