



 **WEXXAR BEL®**

BEL 507

SEMI-AUTOMATIC TILTING CASE FORMER

& PACK STATION

EoL

**END OF
LINE**

BEL 507

SEMI-AUTOMATIC TILTING CASE FORMER & PACK STATION

BEL 507 INCREASES OPERATOR EFFICIENCY AND ERGONOMICS

The BEL 507 forms and holds cases at an angle for quick and easy 2 handed case packing.

Tilting Case Forming for Ergonomic Packing

The BEL 507 is a compact, semi-automatic, tilting case form and pack station designed for manual pack lines. The purpose of the tilting is for ergonomic loading and packing of unstable, tipping, and fragile products.

The BEL 507 also features a quick tool-less size changeover and on-machine pictorial guides for ease of use. With an attached BEL sealer, this machine will greatly increase production line speeds while removing the costs and clutter of having preformed cases.



ABOUT THE BEL 507



EASY CASE SIZE CHANGES

Tool-less case size changes are simple and quick with change points accessible from both operational sides of the machine.

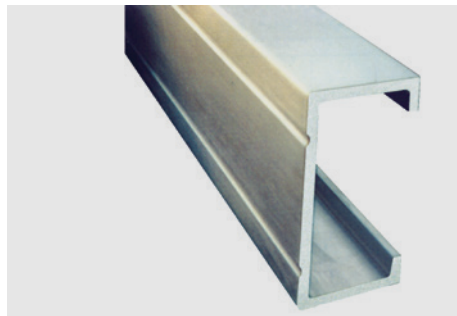

LASTING PERFORMANCE

Corrosion resistant and paint-free construction guards against machine wear and extends machine life.



ON MACHINE INSTRUCTIONS

User-friendly pictorial guides and color-coded labeling for convenient operation and size changes.

COMPLETE SOLUTION

FULLY AUTOMATE YOUR PACKAGING LINE WITH THESE FORMING AND PACKING SOLUTIONS.



BEL 150 CASE SEALER

Semi-automatic tape case sealer provides an effective and reliable solution for top and bottom sealing of a wide range of uniform case sizes.



ACCUMULATION TABLE

Ensures product is delivered continuously and ergonomically to the operator. This allows convenient and quick packing as it keeps the product in reach of the operator.



KDF BOX STAND

One of the most popular accessories for semi-automatic packaging lines. The box stand holds case blanks in a convenient position for quick and ergonomic packing.

CONFIGURATION

Side View

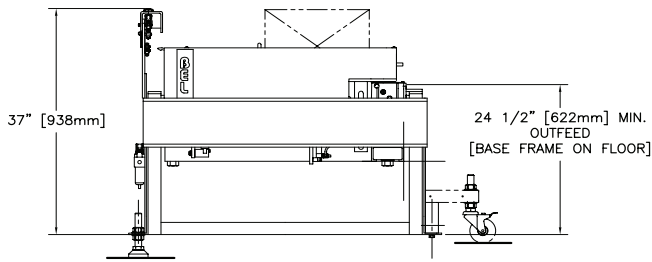

Top View

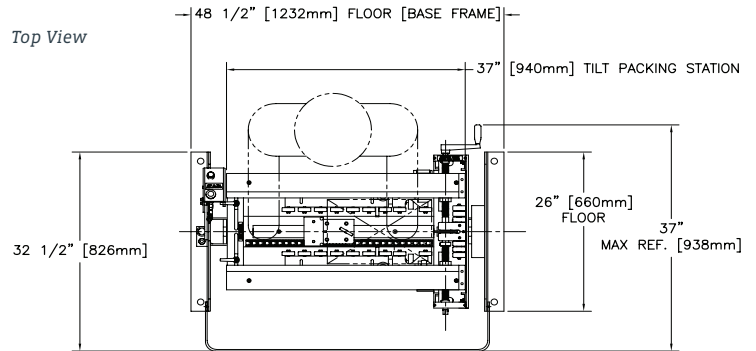

STANDARD FEATURES

- Dynamic flap-folding system power folds all bottom flaps
- Formed cases are positioned on a roller deck for easy loading and transfer to case sealer
- Tilting function to provide ergonomic loading and packing
- Positive mechanical case hold-down keeps box in place for hands-free loading
- 3 point switch actuation protects against accidental starting
- Simple and quick tool-less case size change
- Designed and built in North America with premium materials

OPTIONAL MODIFICATIONS

- Modifications for undersized or oversized cases
- Ergo Level Modification

OPTIONAL ACCESSORIES

- Locking Casters
- Outfeed Table or Conveyor
- Accumulation Table
- KDF Box Stand

PRODUCT SPECIFICATIONS

Machine Weight	500 lbs
Machine Dimensions	48.5"(L) x 26"(W) x 37"(H)
Air	0.15 cubic feet per cycle at 80 p.s.i.
Speeds	up to 7 cases per minute

Specifications are subject to change without notice.

CASE SIZE RANGE

	LENGTH	WIDTH	HEIGHT
Minimum	8" 203 mm	6" 152 mm	3 1/2" 89 mm
Maximum	26 1/2" 672 mm	16" 406 mm	unlimited

INFEEED/OUTFEED HEIGHT

Minimum	24 1/2" (622 mm)
Maximum	31" (762 mm)



At Wexxar Bel, corrugated container packaging applications are limited only by the imagination. Our Wexxar case formers and case sealers have been installed in nearly 40 countries and consistently bring customers the lowest cost of ownership and the highest standards of safety. Wexxar also offers the BEL line of corrugated box sealers, tapers, and packing systems as well as the IPAK line of tray and bliss formers, stackers, and sealers systems. As part of the ProMach End of Line business line, Wexxar helps our packaging customers protect and grow the reputation and trust of their consumers. ProMach is performance, and the proof is in every package.



800.513.9918 | LINCsystems.com