

# SEAL-A-TRON

Shrink Packaging Equipment

**LINC**  
SYSTEMS

800.513.9918 | LINCsystems.com

**PREMIUM  
MACHINERY**  
*at a  
Reasonable  
Price!*



MODEL  
**S-2330**

## SEMI-AUTOMATIC L-BAR SEALER

Seal Bar Dimensions: 23"W x 30"L x 8"H

### Standard Features:

- Tru-Temp Digital Seal Wire Control
- Dual Mag-LOK Extra Strong Magnets
- Lightly Balanced Seal Head Pivot
- EZ-Perf Venting Pin Perf
- Product Discharge Conveyor with Soft Start
- Motorized Seal Table Adjustment
- Proximity Sensor Switching for Impulse Seal Wires
- Anodized Aluminum Seal Head with Film Clamps
- Heavy Duty Welded Frame with Locking Casters

### Options:

- Scrap wind-up
- UL Approved Control Panel
- Hot Knife Upgrade (Electrical Requires 220 VAC)
- Powered Film Unwind (Suggested for rolls over 24"W)
- Adjustable Inverting Plow
- Roller Table Loading Infeed
- Pneumatic Push Button Sealing Cycle
- Heavy Product Upgrades
- Additional Seal Length (Consult Factory)

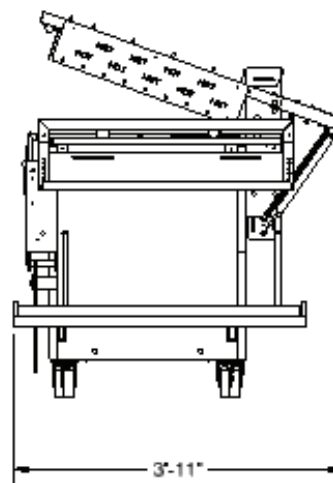
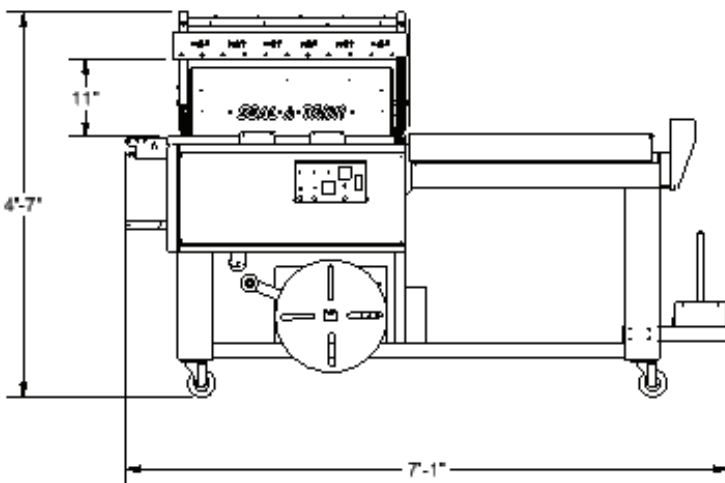

120 VAC

15 Amps

**BUILT FOR  
SERIOUS  
Performance**

For more information, visit [www.LINCsystems.com](http://www.LINCsystems.com)