

SEAL-A-TRON

Shrink Packaging Equipment



800.513.9918 | LINCsystems.com

SEGMENT 1

KOMBI WRAPPER 3 COMBINATION L-BAR SEALER & SHRINK TUNNEL

L-BAR SEALER Standard Features:

SEAL BAR DIMENSIONS: 16" W x 20" x 6" H

- Holds Up to a 20" W Roll of Plastic
- Tru-Temp Digital Seal Wire Control
- Mag-LOK Extra Strong Magnets
- Lightly Balanced Seal Head Pivot
- EZ-Perf Venting Pin Perf
- Proximity Sensor Switching for Impulse Seal Wires
- Anodized Aluminum Seal Head with Film Clamps
- Heavy Duty Welded Frame with Locking Casters
- Power Required:
120 VAC 12 Amp Service

SHRINK TUNNEL Standard Features:

TUNNEL DIMENSIONS: 15" W x 8" H x 30" L

- KOOL-TUCH
- Surround Air Flow All 4 Sides
- .50" Live Rollers on 1.5" Centers
- Digital Temperature Controls
- Cool Down Cycle
- Heavy Duty Shafts and Bearings
- Power Required:
220 VAC Single Phase 30 Amps Service

Options:

- Variable Speed Discharge Conveyor
- Teflon Impregnated GFN Conveyor Belt for Tunnels

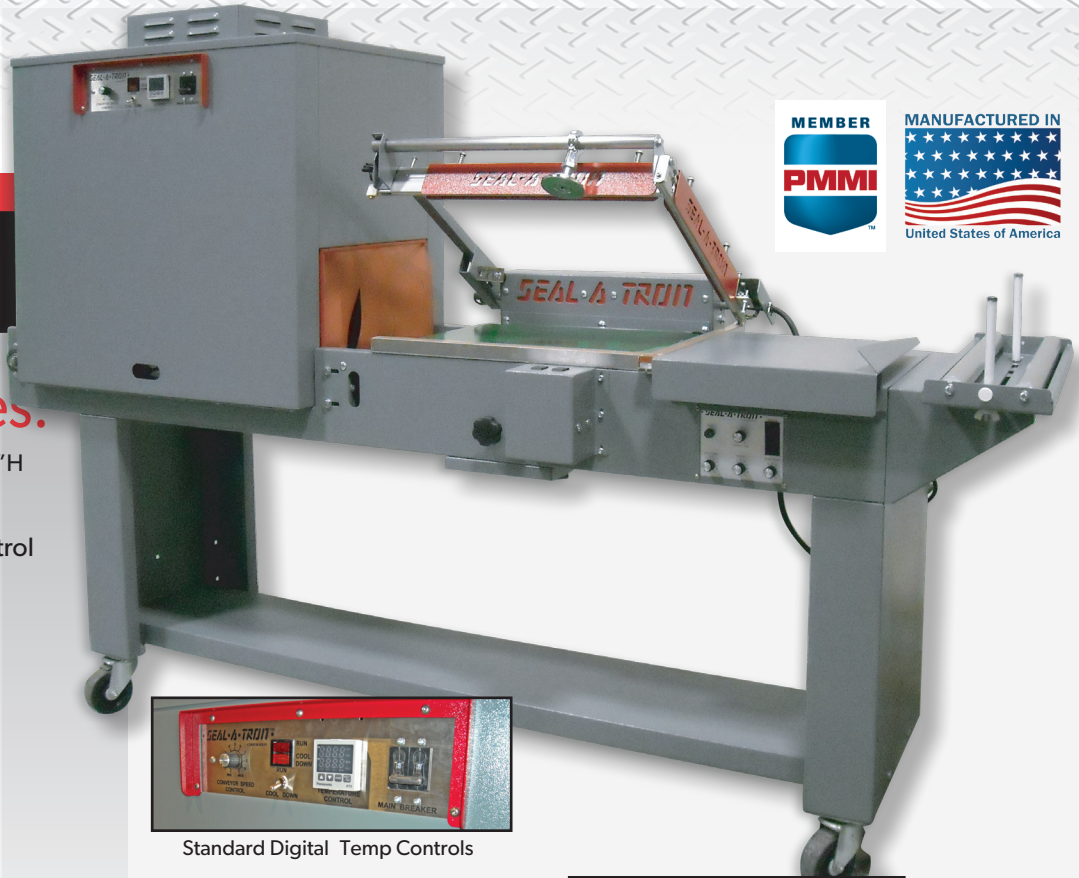

Standard Digital Temp Controls



Optional Teflon Impregnated GFN Conveyor Belt for Tunnels

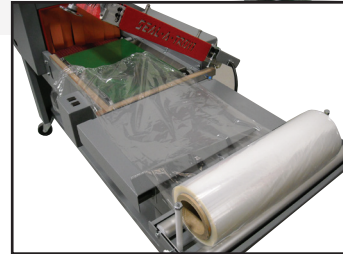

Holds a 20" Roll of Plastic

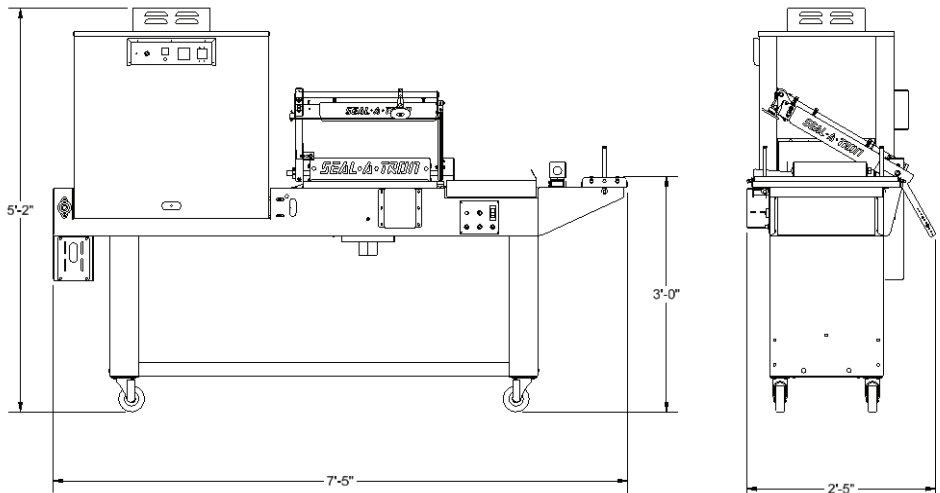

For more information, visit www.LINCsystems.com