

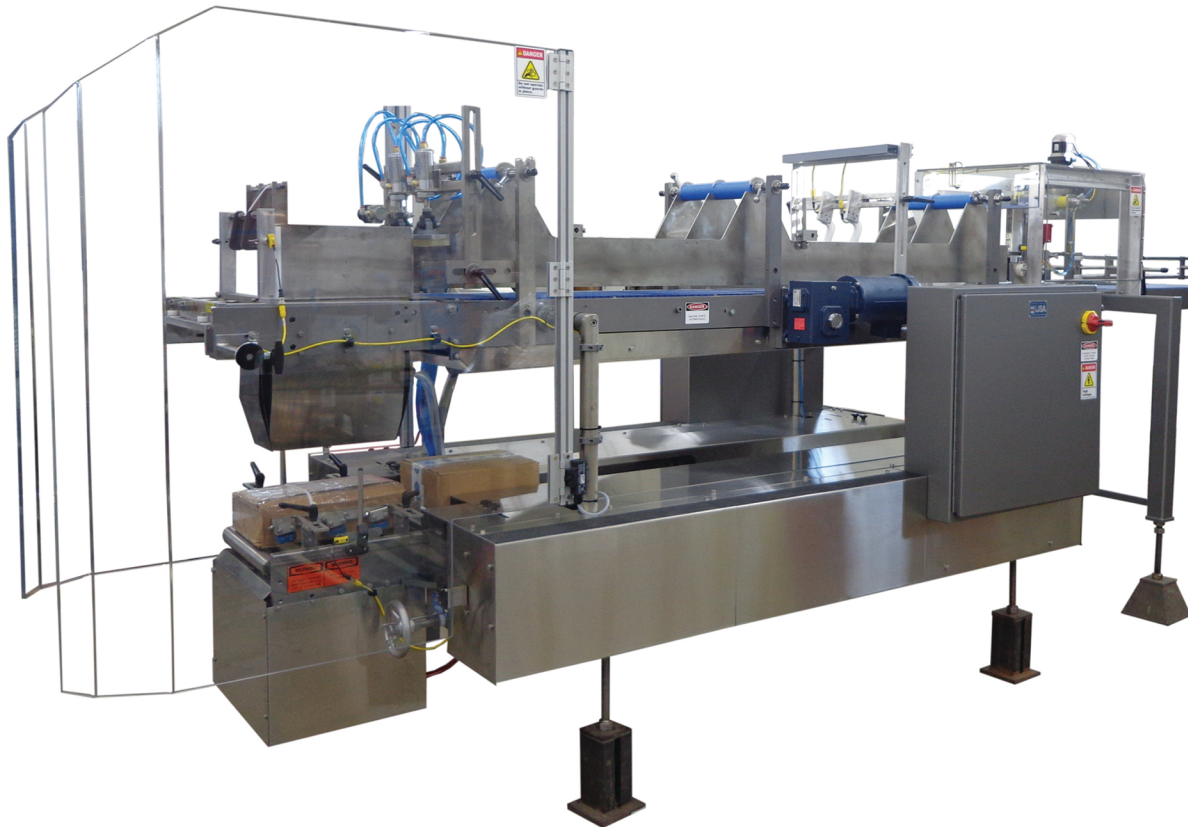

HAMRICK

CHALLENGER "D" DROP PACKER



Round & Non-Round
Containers



25
Cycles Per Minute



Medium to High
Production Volume



HAMRICK

CHALLENGER "D" DROP PACKER

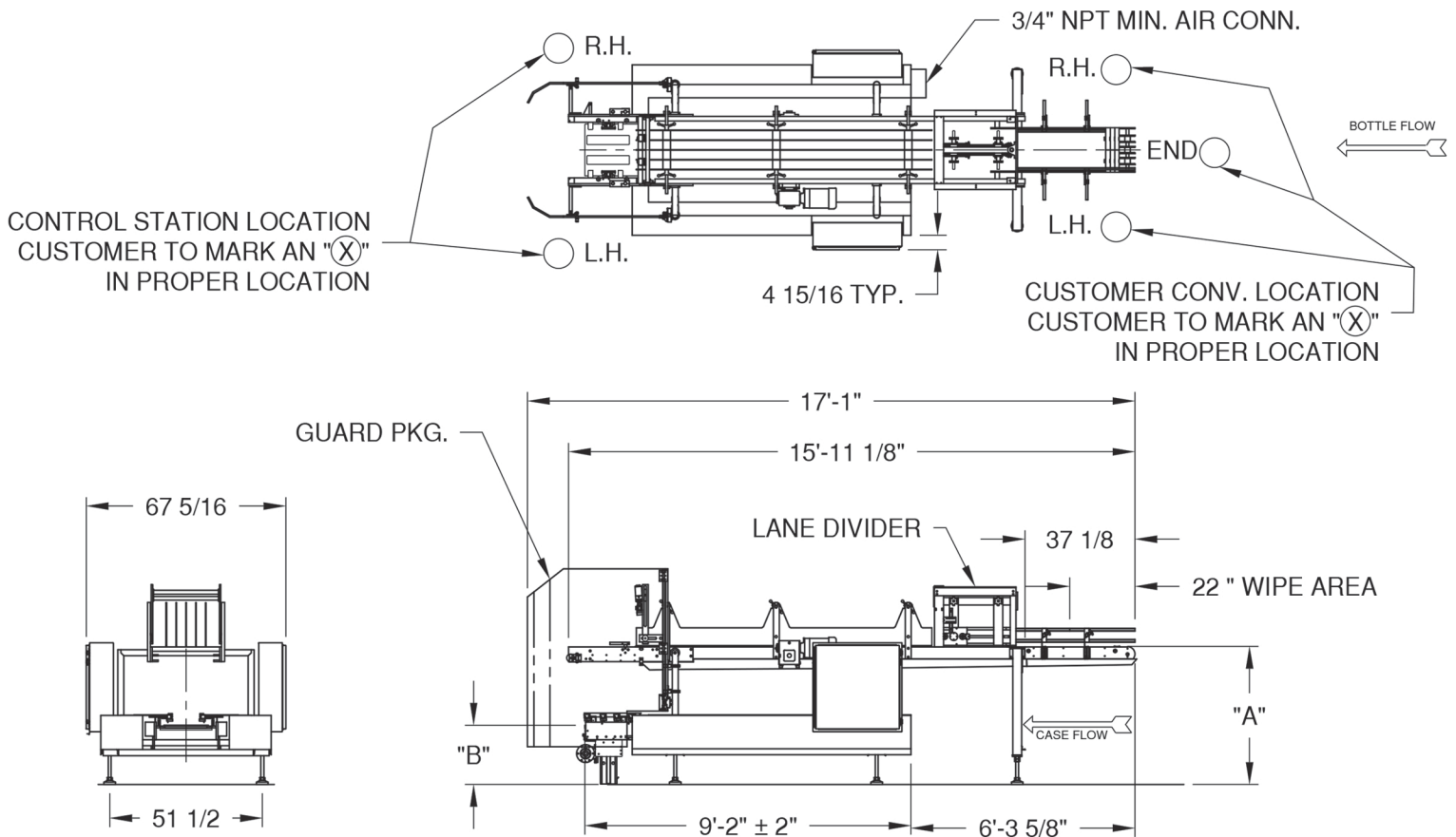

Unit Specifications:

- One (1) packing head included
- Allen-Bradley MicroLogix 1400 PLC
- Stainless steel container and case guides
- Steel-It corrosion resistant paint
- NEMA 12 electrical
- Servo or pneumatic Allen-Bradley lane divider
- Prime and back-up photo eyes

Upgrades Available:

- 90° Bottle turner
- Tab-lock breaker on case lift
- All stainless steel construction with NEMA 4 electrical
- Four flap opener for reshipper cases

One (1) Year Warranty and 100% Money Back Guarantee Always Included