

Version 3
05/2018



Inventor and World n°1 Manufacturer of
Picture Framing Machines & Consumables since 1976

CS 200 CART

Automatic Underpinner



USER & PARTS MANUAL

Read Carefully before using the machine

© Cassese 2014



INDEX

I.	USER MANUAL / ENGLISH.....	5
1	PRESENTATION	6
1.A	WORKING TABLE.....	6
1.B	INTRODUCTION.....	6
1.C	ACCESSORIES SUPPLIED WITH THE MACHINE	7
1.D	TECHNICAL SPECIFICATIONS OF CS200 CART.....	9
1.E	OPTIONS.....	9
1.F	GUARANTEE	9
2	SETUP	10
2.A	UNPACKING THE MACHINE.....	10
2.B	AIR LINE FITTINGS	11
2.C	CONNECTING TO THE AIR SOURCE	11
3	ADJUSTMENTS.....	13
3.A	ADJUSTMENT OF THE SLIDING TABLE.....	13
3.B	PROPER ADJUSTMENT OF MAGNETIC ADJUSTABLE ROD CLAMP	13
3.C	SPECIFIC USE OF THE SPACER BARS	14
3.D	SELECTING THE WEDGES POSITIONS	15
3.E	THREE ESSENTIAL RULES	15
3.F	ADJUSTING THE JOINING ANGLE	15
3.G	MEANS OF JOINING	16
3.H	LOADING OF THE WEDGES	16
3.I	CHANGING WEDGES SIZE	17
3.J	SETTING THE SHOOTING POSITIONS.....	17
4	JOINING THE FRAME	19
5	MAINTENANCE	20
5.A	SAFETY INSTRUCTIONS.....	20
5.B	MAINTENANCE PLAN	20
5.B.a	Daily maintenance:.....	20
5.B.b	Regular maintenance:.....	20
5.B.c	Every 6 months:.....	21
5.C	REMOVING THE DISTRIBUTOR HEAD	21
5.D	LUBRICATING THE DISTRIBUTOR HEAD	22
5.E	UNJAMMING THE MACHINE.....	22
5.F	OPENING THE SIDE PANEL	23
5.G	LUBRICATING THE HORIZONTAL COLUMNS	23
5.H	TESTING THE SAFETIES OF THE MACHINE.....	24
5.I	TROUBLE SHOOTING	24
II.	MANUEL D'UTILISATION / FRANCAIS.....	26
1	PRESENTATION	27
1.A	TABLE D'ASSEMBLAGE	27
1.B	INTRODUCTION.....	28
1.A	ACCESSOIRES FOURNIS AVEC LA MACHINE	28
1.B	SPECIFICATIONS TECHNIQUES	30
1.C	OPTIONS.....	30
1.D	GARANTIE.....	30
2	MISE EN ROUTE.....	31
2.A	DEBALLAGE DE LA MACHINE.....	31

2.B	RACCORDS.....	32
2.C	RACCORDEMENT A L’AIR COMPRIMÉ.....	32
3	REGLAGES.....	34
3.A	REGLAGE DE LA TABLE COULISSANTE.....	34
3.B	REGLAGE DU PRESSEUR VERTICAL.....	34
3.C	UTILISATION DU JEU DE BARRETTES.....	35
3.D	SELECTION DES POSITIONS D’AGRAFAGE.....	36
3.E	TROIS REGLES ESSENTIELLES POUR L’ASSEMBLAGE.....	36
3.F	REGLAGE DE L’ANGLE D’ASSEMBLAGE.....	36
3.G	MOYEN D’ASSEMBLAGE.....	37
3.H	CHARGEMENT DES AGRAFES.....	37
3.I	CHANGER DE TAILLE D’AGRAFES.....	38
3.J	REGLAGE DES POSITIONS D’AGRAFAGE.....	38
4	ASSEMBLAGE DU CADRE.....	40
5	MAINTENANCE.....	41
5.A	INSTRUCTIONS RELATIVES A LA SECURITE.....	41
5.B	PROGRAMME DE MAINTENANCE.....	41
5.B.a	Maintenance quotidienne:.....	41
5.B.b	Maintenance préventive:.....	41
5.B.c	Tous les six mois:.....	42
5.C	DEMONTAGE DE LA TETE DE DISTRIBUTION.....	42
5.D	LUBRIFICATION DE LA TETE DE DISTRIBUTION.....	43
5.E	DEBLOCAGE DE LA MACHINE.....	43
5.F	OUVERTURE DU PANNEAU LATERAL.....	44
5.G	LUBRIFICATION DES COLONNES HORIZONTALES.....	44
5.H	VERIFICATION DES SECURITES DE LA MACHINE.....	45
5.I	GUIDE DE DEPANNAGE.....	46
III.	EXPLODED VIEWS/ VUE ECLATEES.....	47
IV.	SPARE PARTS LIST / NOMENCLATURE.....	59
V.	PNEUMATIC SCHEMATIC / SCHEMA PNEUMATIQUE.....	63
VI.	CE CERTIFICATE / DECLARATION DE CONFORMITE.....	64

I. USER MANUAL / ENGLISH

Your safety is our priority



This symbol on the machine reminds the operator to wear acoustic protections before operating this joiner.



This symbol on the machine reminds the operator to read this manual before operating this joiner.



This symbol in the manual is to mention safety instructions.



This symbol in the manual is to mention some tricks that can help you saving time or improve your production.



This symbol in the manual is to mention needed tools to perform a procedure.

PRIOR TO PERFORM ANY MAINTENANCE, MACHINE MUST BE LOCKED AND UNPLUGGED FROM AIR SUPPLY, REFER TO CHAPTER I.5.A SAFETY INSTRUCTIONS (PAGE 20). DO NOT OPERATE THE MACHINE IF COVERS OR PROTECTIONS ARE MISSING.

1 PRESENTATION

1.A WORKING TABLE

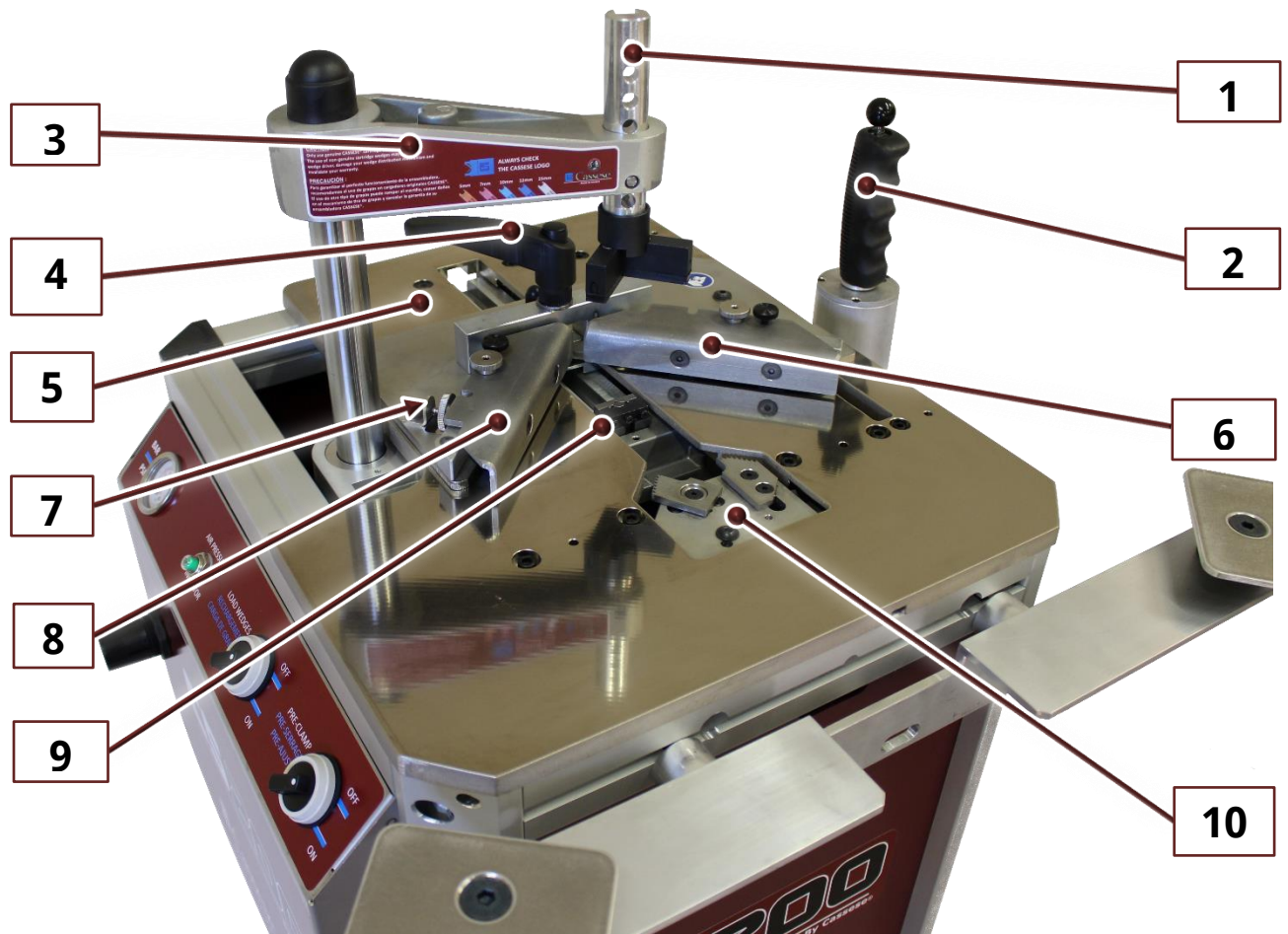

English

Magnetic adjustable rod clamp assembly	1
Joystick	2
Crossbar	3
Word impossibSliding table handle	4
Sliding table	5
1 st back fence	6
Angle adjusting screw	7
2 nd back fence	8
Wedge distributor	9
Rebate clamp	10
Clamp pressure regulator	11
Air pressure gauge	12
Air pressure indicator	13
Wedge loading button	14
Pre-clamping button	15
Air valve	16
Inside stop's position handle	17
Outside stop's position handle	18



1.B INTRODUCTION

Thanks for having purchased the CS200 CART underpinner and for your trust in Cassese® products. The CS200 CART benefits from Cassese's experience since 1976 in designing and manufacturing highest quality underpinners, for which we are world-famous. The CS200 CART will allow you to join, wooden, plastic and MDF profiles (patent n° 7522814). Joining operation is carried out by using Genuine Cassese® Cartridge Wedges, specially designed to perform perfect and tight frames' corners.

1.C ACCESSORIES SUPPLIED WITH THE MACHINE



Z26999:
1 x Magnetic adjustable rod clamp

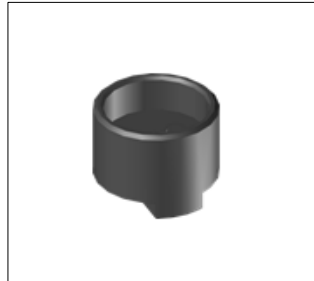

Z24703:
1 x Chevron holder



Z21525:
1 x Chevron rubber assy



Z506:
1 x Wedge driver blade for using CASSESE® Genuine Cartridge Wedges



Z1879:
1 x Allen Key 2.5 mm



Z1882:
1 x Allen Key 3 mm



Z1884:
1 x Allen Key 4 mm



Z1885:
1 x Allen Key 5 mm

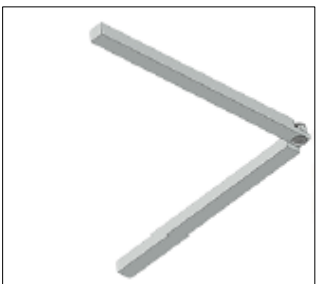

Z3078:
Spacer bars



Z1896:
1 x Grease Tube



1 box of 7 mm Softwood
1 box of 10mm Hardwood
1 box of 10mm Softwood



Z535:
Wedge removal tool

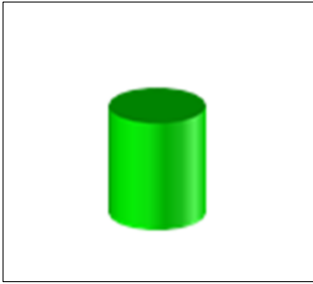

Z1791:
Green round clamp

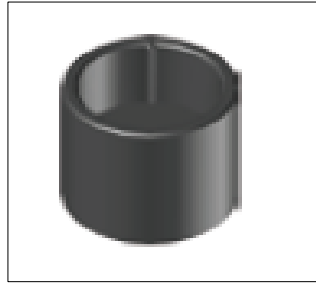

Z18065:
Round clamp holder

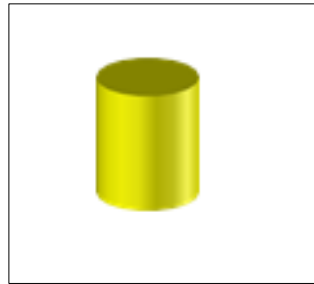

Z1783:
Yellow round clamp

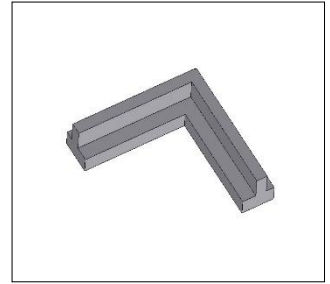

Z21524:
1 x Chevron rubber



Z1343 (x4):
Nut
Z1612 (x4):
Washer
Z25780 (x4):
Levelling feet



Z749:
Quick coupling



Z556:
Grooved connector



Z701:
Male US connector F1/4

1.D TECHNICAL SPECIFICATIONS OF CS200 CART

<u>Minimum moulding width:</u>	5mm (3/16") / Minimum moulding height : 7 mm (1/4")
<u>Maximum moulding width :</u>	150 mm (5 29/32") / Maximum moulding height : 100 mm (4 13/32") Maximum stroke between first and last wedge (at 45°) : 190 mm (7 31/64")
<u>3 wedge types :</u>	Softwood, Hardwood & MDF. Use only Cassese® Genuine Cartridge Wedges. Cassese® Genuine Cartridge Wedges sizes: 5, 7, 10, 12 and 15 mm.
<u>Machine gross weight :</u>	44 kg .
<u>Dimensions :</u>	Width 600mm (2ft 219/64") x Depth 589mm (1ft 113/16") x Height 1171mm (3ft 107/64").
<u>Air Supply :</u>	Compressed air 6-7 bars
<u>Average consumption per cycle :</u>	2 NI at 6 bars (we consider one cycle is a corner with 2 positions and 1 wedge per position)

1.E OPTIONS



Z25147:
Stainless steel shelf for
wedges and accessories

1.F GUARANTEE

One year guarantee for parts and labor against manufacturing defects. Wearing parts* and those damaged as a result of non-appliance with the instructions of the present manual are excluded from the guarantee.

**Chevron rubbers, round clamps and wedge driver blades are considered as wearing parts.*

2 SETUP

2.A UNPACKING THE MACHINE

	<p>Cutter Flat span N.13 & N.17 Allen key N.5</p>	<p>Bubble level</p>
---	---	---------------------

Cut both plastic strips in order to free the box and lift up the wood cover with the help of a second person.



Figure 2-1

Remove the 4 bolts to free the machine from the crate. They are located under the pallet.



Figure 2-2

After unpacking the machine, install and set the 4 feet to level the machine. Make sure the 4 feet are touching the floor, machine must be steady.

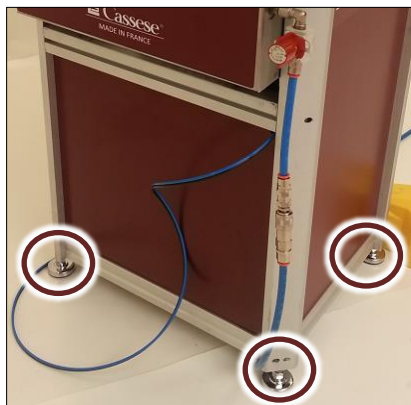

Figure 2-3



When levelling the machine, if the machine is installed against a working table, make sure a long frame will not be risen up by the table, because this would cause bad joining. Working table and machine should be levelled together.



When installing the machine, make sure the floor will be flat and strong enough to support its weight. It should be installed in a dry environment providing temperate temperature. The floor should be flat and clean. Select a location with proper lighting.

2.B AIR LINE FITTINGS

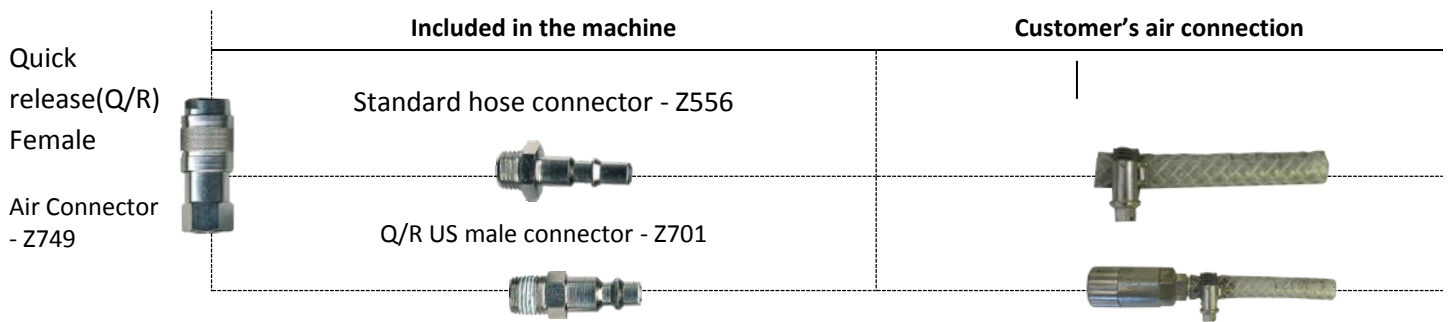

2.C CONNECTING TO THE AIR SOURCE

The machine should be connected to a pneumatic circuit providing 6 to 8 bars pressure.

Connect the machine using the quick connectors as mentioned in chapter 0

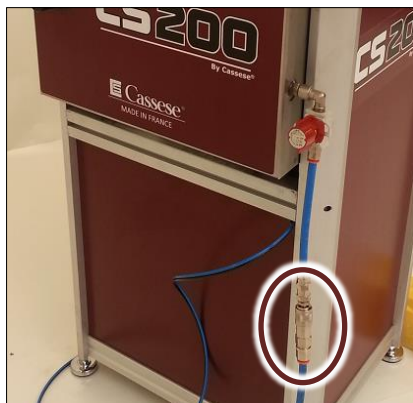

Figure 2-4

The CS200 CART must be connected to the air source located on the front panel of the drawer. Turn the compressed air valve to **ON** by rotating its red knob .

The air pressure gauge should show 6 bars (85 p.s.i.) minimum.



Figure 2-5



The red knob in Figure 2-5 must be used to secure the machine during maintenance or to prevent non desired use. A lock can be applied to it in stop position so nobody can turn it back to ON. This will exhaust air from the machine circuit and disconnect it from air supply. Refer to chapter I.5.A SAFETY INSTRUCTIONS (page 20) for further instructions.

If the indicated pressure is not 6 bars (85 p.s.i.), check the pressure at the air source (compressor). Then, if pressure is correct at the air source, it means the regulator of the machine needs fine tuning. Perform the following procedure to adjust it (Figure 2-6 and Figure 2-7)



Flat span N.10

Hold the top of the panel with one hand. Unscrew of 1 turn both screws of the drawer panel with a N.10 flat span. DO NOT REMOVE THESE SCREWS. Then open the drawer to have access to the air pressure regulator knob.



Figure 2-6

Pull the air pressure regulator knob and turn it (clockwise = more pressure) until the needle of the air pressure gauge reaches 6 bars (85p.s.i.).

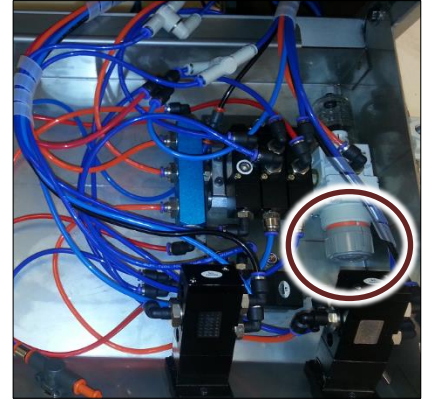

Figure 2-7

3 ADJUSTMENTS

3.A ADJUSTMENT OF THE SLIDING TABLE

The sliding table (see page 6) needs to be adjusted to be able to set the various stapling positions.

To do this, switch on the Pre-Clamp button.



Figure 3-1

Unscrew the sliding table handle.

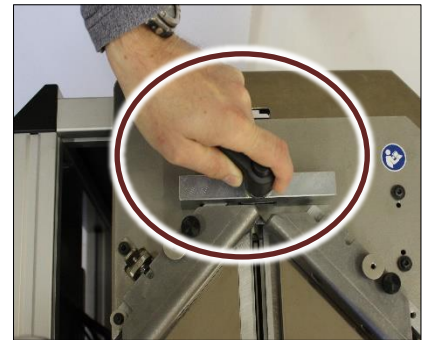

Figure 3-2

Install one moulding on the table as per picture attached.

Shift the sliding table in order to tighten the moulding with the rebate clamp (see page 6).

Then tighten the sliding table handle.



Figure 3-3

Switch back off the Pre-Clamp button in order to release the mouldings and remove the moulding that was against the back fence.



Figure 3-4

English

3.B PROPER ADJUSTMENT OF MAGNETIC ADJUSTABLE ROD CLAMP

A magnetic adjustable rod clamp comes with your machine as a standard feature. It fits the crossbar thanks to the locking ring and can be set at 1 to 7 positions.



Figure 3-5

Pull the black knob to be able to adjust the space between the vertical clamp and the top of the moulding. You must have 50mm (2") max between the clamp and the top of the moulding.

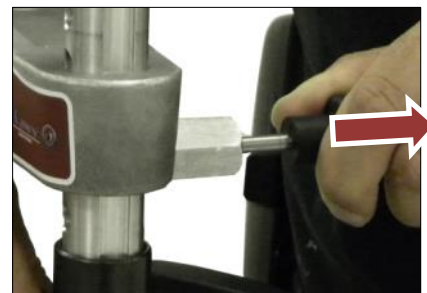

Figure 3-6



When adjusting the vertical rod clamp, closer it is from the top of the moulding, and faster will be the machine. The machine will not damage the moulding, even if the distance is very close. If the distance is superior to 50mm, the wedge will not penetrate fully inside the wood.

Pay attention to properly position the magnetic chevron clamp: the sides of the chevron must be parallel to back fences 1 and 2.

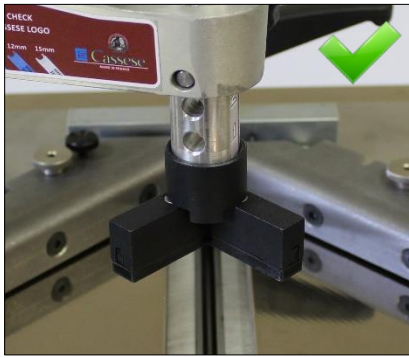

Figure 3-7

Example of bad setting of the chevron.

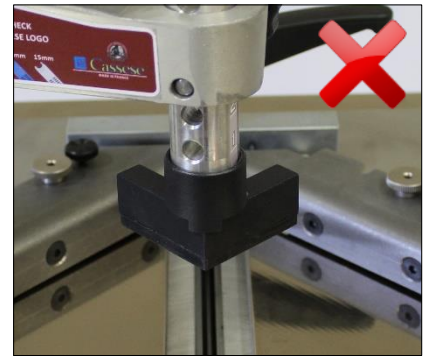

Figure 3-8

Now with quick-change magnetic clamps, it is easy to change from chevron to a round clamp. Simply pull down the Z24703 to change of clamp support.



Figure 3-9

3.C SPECIFIC USE OF THE SPACER BARS

When joining small mouldings (lower than the height of the back fences), it is necessary to use the set of spacer bars supplied with the machine.

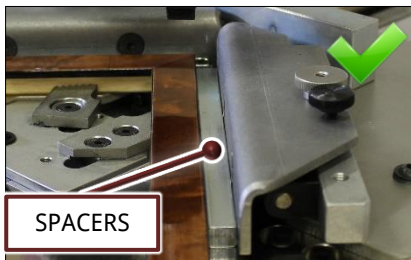

Figure 3-10

This is an example of a bad setting, the spacer bar not being used will cause the top clamp not to hold the moulding correctly. The moulding will jump up during stapling.



Figure 3-11

The spacer bars are made of two steel bars linked with a screw locked by a nut. The nut side is the bottom side of the spacer bars



Figure 3-12

Here the spacer bars are upside down. The nut is visible on the top, which is not correct.



Figure 3-13

3.D SELECTING THE WEDGES POSITIONS

The CS200 CART is designed to join mouldings in 2 positions that will be selected using side handles, but you can stop in any other position between the 2 extreme positions. You can stack several wedges in each position.

3.E THREE ESSENTIAL RULES

- 1- A MINIMUM 2 mm clearance (less than 1/8") above the wedges shall be respected.
- 2- Same size wedges can be stacked up in order to avoid having to change the wedge size when joining mouldings with different thickness.
- 3- The wedge positions should be lined up to the highest points of the moulding.

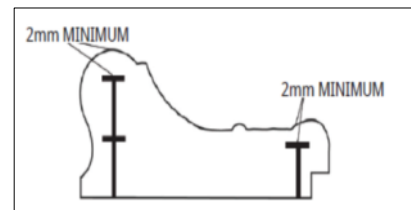

Figure 3-14



When selecting the position of the top clamp, always pay attention to its contact surface with the moulding. Select positions that will provide steady seating.

3.F ADJUSTING THE JOINING ANGLE

If the corner is opened towards outside

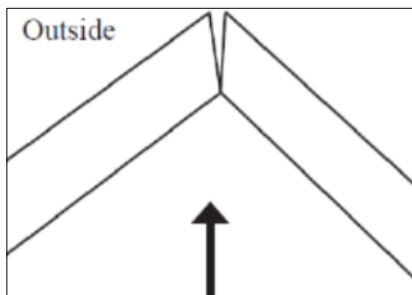

Figure 3-15

Tighten the adjusting screw to correct the defect of the mouldings.

Check the quality of the angle by clamping the corner against the back fences again.



Figure 3-16

If the corner is opened towards inside.

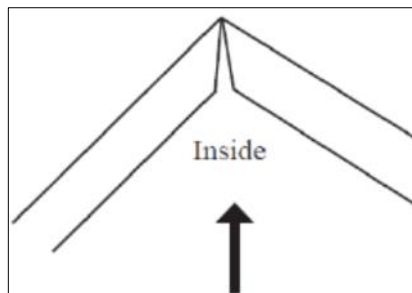

Figure 3-17

Loosen the adjusting screw to correct the defect of the mouldings.

Check the quality of the angle by clamping the corner against the back fences again.



Figure 3-18

If you get this result : it means your cutting angle is less than 45°.

Your cutting machine needs to be set to the right 45° angle (check your cutting machine's user manual to make this adjustment).

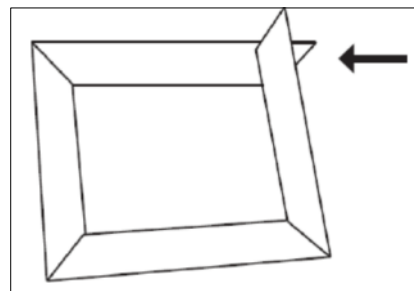

Figure 3-19

3.G MEANS OF JOINING

Thanks to the color code, you can recognize and select easily the type of Vnails to be used. Please note that hard wood Vnails will have a yellow pusher to help identifying them. A white pusher will indicate soft wood Vnails.

See color chart bellow for identification.

Cassese wedges can also be supplied in MDF type dedicated to MDF or very hard wood use. They are identified by a red pusher in the cartridge. Please contact your local agent to try them.

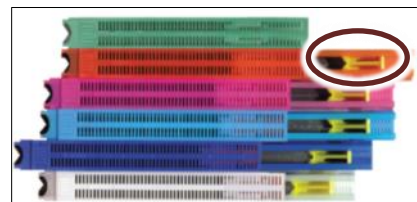

Figure 3-20

	BOX OF 6 CARTRIDGES		BOX OF 40 CARTRIDGES		
	SOFT WOOD	HARD WOOD	SOFT WOOD	HARD WOOD	MDF
15 mm wedges	30315NC0l	31315BDC0	30415NC0l	31415BDC0	31415MDF
12 mm wedges	30312NC0l	31312BDC0	30412NC0l	31412BDC0	31412MDF
10 mm wedges	30310NC0l	31310BDC0	30410NC0l	31410BDC0	31410MDF
7 mm wedges	30307NC0l	31307BDC0	30407NC0l	31407BDC0	31407MDF
5 mm wedges	30305NC0l	31305BDC0	30405NC0l	31405BDC0	
3 mm wedges	30303NC0l		30403NC0l		

English



It is recommended to use the proper type of wedges for joining, always using hard wood wedges in all your frame will result in poor tightening of the corner when the wood is soft. A first approach consists in trying to scratch the wood with your nails, if you can scratch it easily, then a soft wood wedge should do the job perfectly and you will get the best tightening.

3.H LOADING OF THE WEDGES

To load the machine, rotate the loading button in the ON position.

The wedge pusher will move back to allow you to introduce the cartridge.



Figure 3-21

Load the cartridge and turn back the loading button to off.



Figure 3-22

3.I CHANGING WEDGES SIZE

Repeat procedure of Figure 3-21, then remove the cartridge and insert another cartridge of a different color. Thanks to the cartridge system, no need to adjust anything nor change any head.

Then turn back OFF the loading button.

3.J SETTING THE SHOOTING POSITIONS

After performing the adjustments of chapter 3 (ADJUSTMENTS). Perform the following procedure:

Put on the table only one chop of moulding against the fence as per picture. This will allow easy visualization of stapling positions

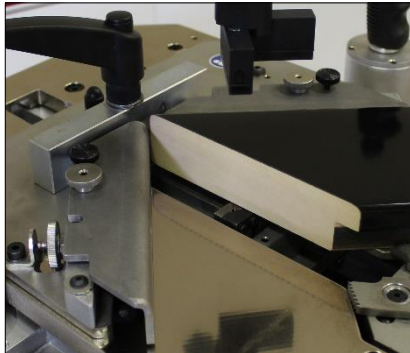

Figure 3-23

Rotate the pre-clamping button in the ON position.



Figure 3-24

Rotate the joystick to be able to move to the inside shooting position. Once the desired position is reached, release the joystick.

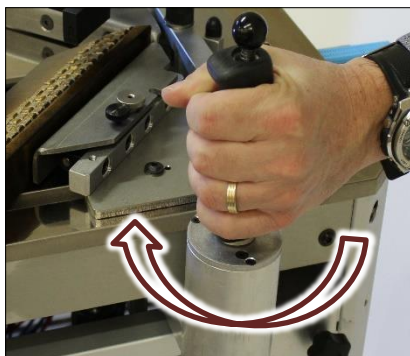

Figure 3-25

Unlock the stop position handle.

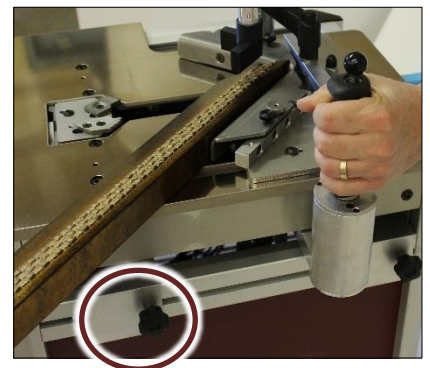

Figure 3-26

Move the stop to the joystick assy until it hits the aluminum support of the joystick. Lock the handle of the stop. This will set your extreme inside position.

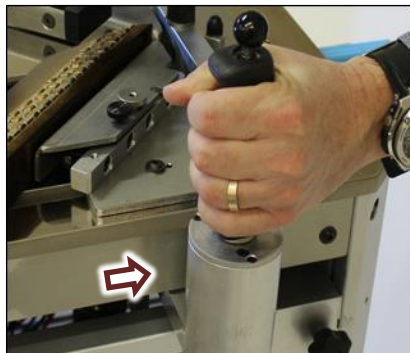

Figure 3-27

Rotate the joystick to be able to move to the outside shooting position. Once the desired position is reached, release the joystick.

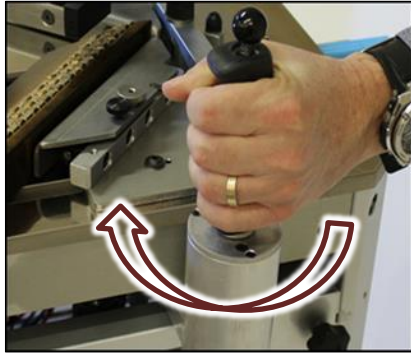

Figure 3-28

Unlock the external stop position handle.

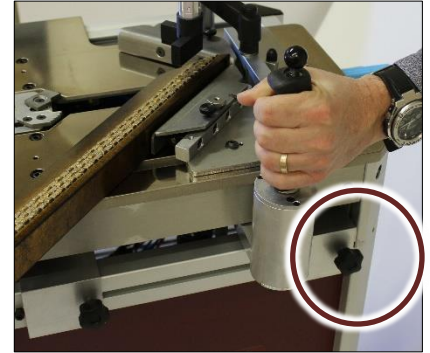

Figure 3-29

Move the stop to the joystick unit until it hits the aluminum support of the joystick. Lock the handle of the stop. This will set your extreme external position.

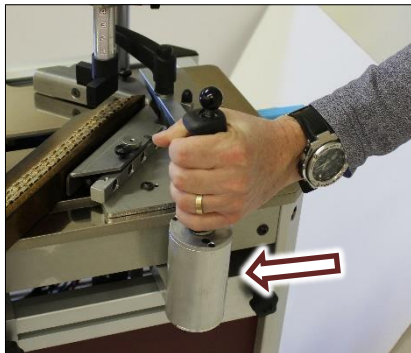

Figure 3-30

Rotate back the pre-clamping button in the OFF position.



Figure 3-31

4 JOINING THE FRAME

Put The right side moulding on the table as per image. Then push the moulding until it reaches the opposite stop. Put the second moulding on the table.

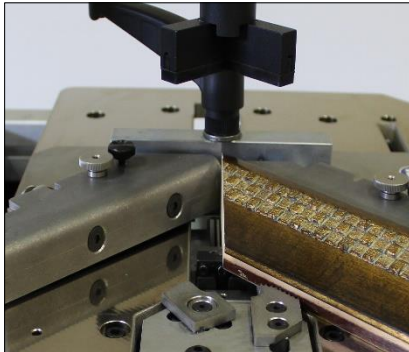

Figure 4-1

Rotate the joystick and move it to the desired stop. Joining can be done starting from inside or outside position.

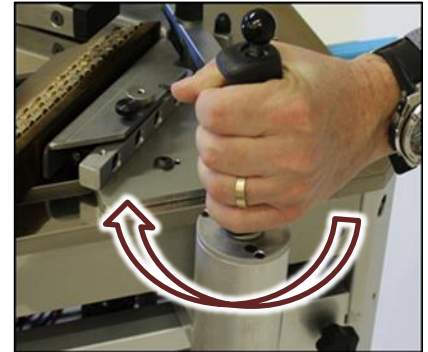

Figure 4-2

Press the pedal to clamp the mouldings together. The horizontal clamps will move up to the moulding.



Figure 4-3

Press the top button of the joystick to insert the wedge inside the moulding. **Keep the button pressed until the machine releases the vertical clamp.** Press a second time the button if another wedge needs to be stacked in this position. Keep pedal pressed during this process.



Figure 4-4

Rotate the joystick and move it to the second stop.



Figure 4-5

Still with the pedal pressed, press the top button of the joystick to insert the wedge inside the moulding. **Keep the button pressed until the machine releases the vertical clamp.** Press a second time the button if another wedge needs to be stacked in this position. Keep pedal pressed during this process.



Figure 4-6

Release the pedal once the joining is done. It is possible also to shoot wedges (and even to stack them), between the two stops.

5 MAINTENANCE

5.A SAFETY INSTRUCTIONS



The CS200 CART is using pneumatic air supply. It is essential for your safety to make sure that it is disconnected prior to make any maintenance. Please refer to instructions below prior to perform any maintenance.

Rotate red button in EXH position.

Unplug the machine from pneumatic source.

Install a locker to ensure nobody will turn back on the machine while you will be performing the maintenance.



Figure 5-1



If using compressed air to clean some parts, wear safety glasses. It is even recommended to use a vacuum to clean the machine rather than compressed air that will spray dust everywhere.

All maintenance and control operations must be carried out by skilled maintenance staff.

5.B MAINTENANCE PLAN

5.B.a Daily maintenance:

It is recommended once a day to clean the table surface with a clean cloth and make sure there is no debris in the distributor head. If some glue is remaining in the distribution block, then perform procedure 5.C REMOVING THE DISTRIBUTOR HEAD (page 21) and 5.D LUBRICATING THE DISTRIBUTOR HEAD (page 22). It is important to avoid glue from drying in the distribution head as it could prevent the cartridge from going in the distribution block correctly.

5.B.b Regular maintenance:

Once a week it is recommended to clean and lubricate the distribution block. Refer to following chapter to perform this maintenance:

5.A SAFETY INSTRUCTIONS (page: 20)

5.C REMOVING THE DISTRIBUTOR HEAD (page 21)

5.D LUBRICATING THE DISTRIBUTOR HEAD (page 22)

5.B.c Every 6 months:

Every 6 months a maintenance should be performed to ensure proper function of the machine, perform the following procedure to do it:

- 5.A SAFETY INSTRUCTIONS (page 20)
- 5.C REMOVING THE DISTRIBUTOR HEAD (page 21)
- 5.D LUBRICATING THE DISTRIBUTOR HEAD (page 22)
- 5.F OPENING THE SIDE PANEL (page 23)
- 5.G LUBRICATING THE HORIZONTAL COLUMNS (page 23)
- 5.H TESTING THE SAFETIES OF THE MACHINE (page 24)

5.C REMOVING THE DISTRIBUTOR HEAD

Periodically, remove the distributor head to clean and lubricate it. First, remove the strip of wedges. To do so, follow this procedure :



Allen key N.2 & N.5

To load the machine, rotate the loading button in the load position.

The wedge pusher will move back to allow you to introduce the cartridge.



Figure 5-2

Remove the cartridge.



Figure 5-3

With the 2.5mm Allen Key, unscrew the locking screw half a turn.



Figure 5-4

Pull out the distributor head of the machine.



Figure 5-5

5.D LUBRICATING THE DISTRIBUTOR HEAD



Allen key N 2.5
Grease tube, Cassese reference Z1896

Lubricant spray, for example WD40.

Remove all the screws of the distributor head.



Figure 5-6

Separate the distributor plates and clean them using a clean cloth and lubricant spray. The two small screws are dedicated to the internal square rod



Figure 5-7

Insert the equivalent of a nut of grease in the bottom of the distributor head.

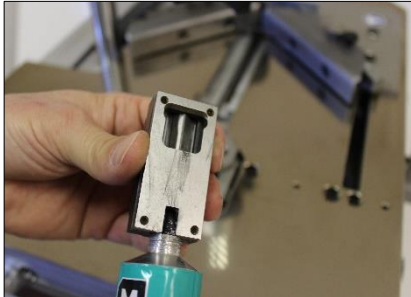

Figure 5-8

5.E UNJAMMING THE MACHINE



Wedge removal tool Z535

Sometime a wedge or a driver blade can stuck in top position.



Figure 5-9

Use the tool to try to push down the wedge in the distribution head. The tool needs to be inserted only of about 5mm in the distribution head, then remove the tool and try to remove the cartridge.

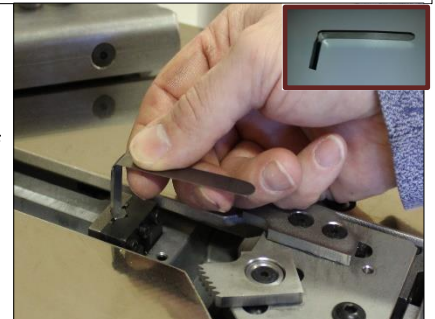

Figure 5-10

If you can't push down the protruding Wedge/driver blade, then put your hands on top of the vertical column and give a shock down. An audible "clack" sound should confirm the hammer is unlocked.

Try to apply procedure I.5.C REMOVING THE DISTRIBUTOR HEAD (page 21) to remove the distributor and be able to remove the jammed hammer. If the distributor head can't be removed, apply again a shock down and try to remove the distributor.

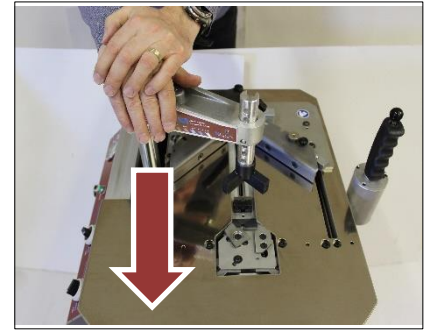

Figure 5-11



Never push with your finger on a protruding wedge, they are very sharpened!!!

5.F OPENING THE SIDE PANEL



Flat span N.10

Unscrew of 1 turn both screws of the drawer panel with a N.10 flat span.

DO NOT REMOVE THESE SCREWS

Then open the drawer to have access to the air pressure regulator knob.



Figure 5-12

5.G LUBRICATING THE HORIZONTAL COLUMNS



Flat span N.10
Clean cloth with lubricant spray such as WD40
Engine car oil

Refer to chapter I.5.A SAFETY INSTRUCTIONS (page 20) for safety instructions.

Open the side panel as explained in the chapter I.5.F OPENING THE SIDE PANEL (page 23).

Clean with clean cloth the 2 horizontal columns and apply some engine car oil on them.

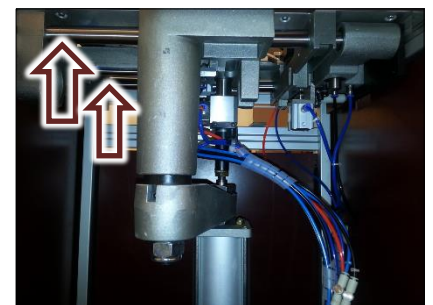

Figure 5-13

5.H TESTING THE SAFETIES OF THE MACHINE

For your safety, do not put your hands on the tables, make sure there is nothing on them. Remove any moldings from the machine.

Press the pedal and check that the clamps are moving forward then backwards as soon as the pedal is released.

If not, contact your local agent to replace the pedal assembly.



Figure 5-14

For your safety, do not put your hands on the tables, make sure there is nothing on them. Remove any moldings from the machine.

Remove the wedges from the machines, refer to chapter I.3.H LOADING OF THE WEDGES (page 16).

Press the pedal, keep the pedal pressed. While doing so, press the shooting button. The machine shouldn't try to shoot with no moulding. If it tries to staple, then contact your local agent for repair.



Figure 5-15



*In case of problem, it is possible to release the pedal or the shooting button to interrupt the joining process. If a wedges was engaged in the distribution block, apply procedure I.5.E **UNJAMMING THE MACHINE** (page 22) to remove that wedge.*



Make sure the machine is complete and that no part was removed, all side panels must be closed and all screws in place. In case of missing item, use exploded views to order the missing part. Missing side panel will expose moving part which is dangerous for operators.

5.I TROUBLE SHOOTING

if your machine is not working properly, please refer to FAQ bellow, if the solution of your trouble is not in this section, please contact your local distributor or contact us on our web site: www.cassese.com.

No wedges is inserted into moulding:

- > Cartridge is empty.
- > There is some dirt in the distributor block which doesn't allow the wedges to be shoot (wedges will not be at the right place and won't be pushed by the hammer).
- > Hammer is damaged, remove the distribution block to check it. See chapters bellow:
 5.A SAFETY INSTRUCTIONS (page 20)
 5.C REMOVING THE DISTRIBUTOR HEAD (page 21)

Wedge does not penetrate fully in moulding:

- > Pedal is released too early. During a stapling, make sure the pedale is pressed until the top bung returns to top position by itself.
- > Moulding is too small causing the bung to touch the fences. Refer to chapter 3.C SPECIFIC USE OF THE SPACER BARS (page 14).
- > Check the air pressure of the compressor or the machine, see chapter 2.C CONNECTING TO THE AIR SOURCE (page 11).
- > The distance between the bung and the moulding is too height, follow insructions of chapter 3.B PROPER ADJUSTMENT OF MAGNETIC ADJUSTABLE ROD CLAMP(page13) to set it correctly.
- > Try to use a harder bung (green color or chevron type).
- > Hammer is damaged, remove the distribution block to check it. See chapters bellow to do that:
5.A SAFETY INSTRUCTIONS (page 20)
5.C REMOVING THE DISTRIBUTOR HEAD (page 21)
- > End of travel sensor out of adjustment: contact your local dealer for technical support.

Wedge is breaking in the wood:

- > Try to use hard wood wedges or MDF wedges.
- > The backs are stained.

The clamps are working but the top bung doesn't move down.

- > The horizontal clamps are too far away from the mouldings. Repeat the pre-clamping procedure described in chapter I.3.A ADJUSTMENT OF THE SLIDING TABLE (page 13). If this procedure is not followed or if the sliding table is not well locked, the machine will not detect the presence of the moulding. A safety is then activated to prevent any accident.

The distributor is full of grease.

- > Perform the procedure described in chapter 5.C REMOVING THE DISTRIBUTOR HEAD (page 21) and remove any excess grease. Do some stapling in scrap mouldings to purge any excess. Then wipe off the top of the distribution head.

Handling the mouldings is difficult.

- > The horizontal clamps are too tight against the mouldings. Repeat the pre-clamping procedure described in chapter I.3.A ADJUSTMENT OF THE SLIDING TABLE (page 13).

The corners are crooked.

- >Make sure to place the first moulding against stop as Figure 3-23.

II. MANUEL D'UTILISATION / FRANCAIS

« VERSION ORIGINALE »

Votre sécurité est notre priorité



Ce marquage sur la machine vous recommande le port de protections auditives.



Ce marquage sur la machine vous recommande de lire le manuel avant toute utilisation.



Cette icône dans le manuel met l'accent sur un point important relatif à la sécurité.



Cette icône dans le manuel vous signale une astuce susceptible de vous faire gagner du temps ou d'améliorer votre production.



Cette icône dans le manuel vous permet de connaître la liste des outils nécessaires pour effectuer une procédure.

AVANT TOUTE MAINTENANCE SUR CETTE MACHINE, DEBRANCHER ET VERROUILLER L'ALIMENTATION PNEUMATIQUE. NE PAS UTILISER LA MACHINE SI UN COUVERCLE OU UNE PROTECTION EST ABSENT. SE REPORTER AU CHAPITRE II.5.A INSTRUCTIONS RELATIVES A LA SECURITE (PAGE 41) POUR GARANTIR VOTRE SECURITE.

1 PRESENTATION

1.A TABLE D'ASSEMBLAGE

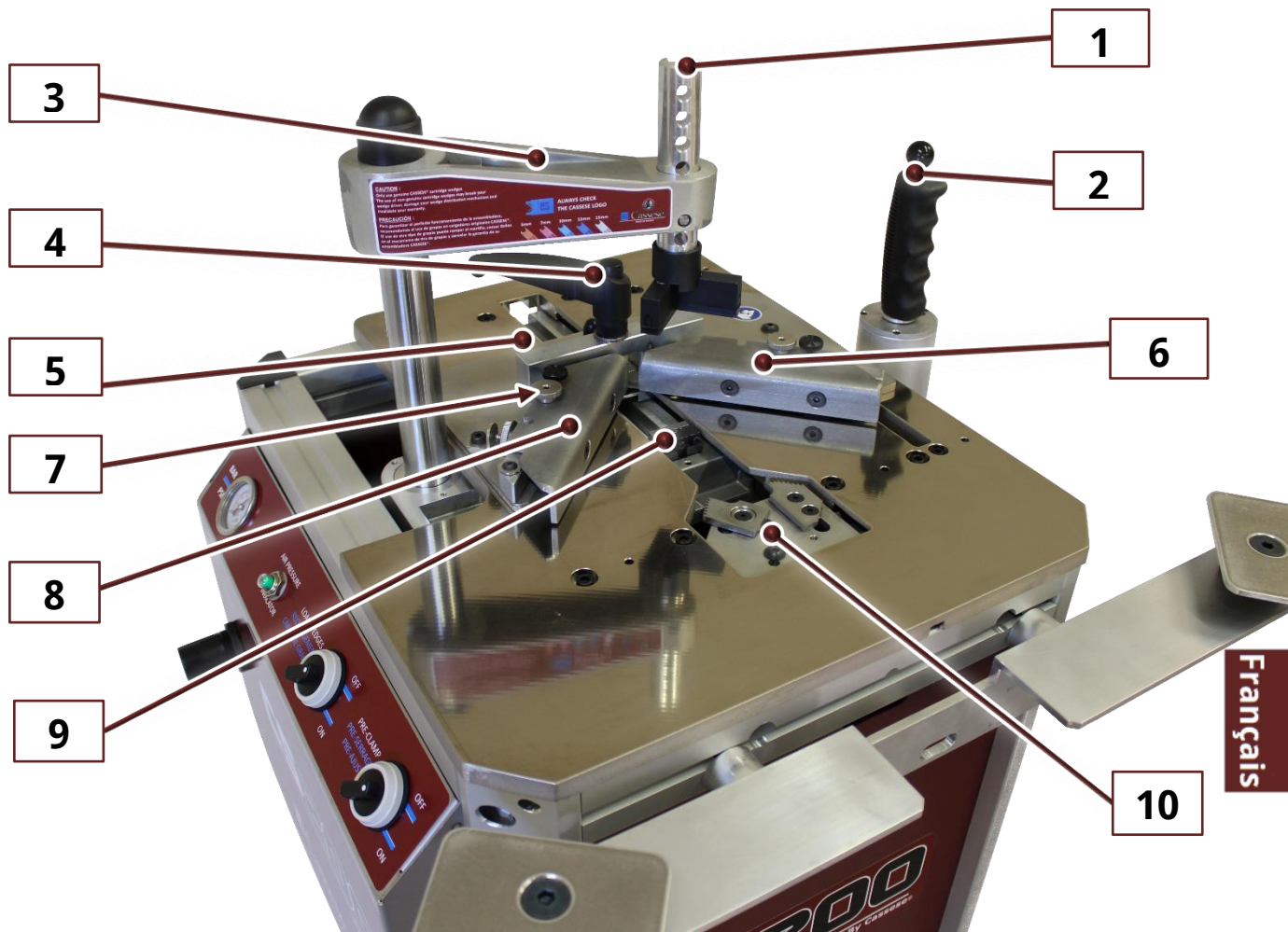

Français

Presseur réglable	1
Joystick	2
Potence	3
Manette de verrouillage de la table coulissante	4
Table coulissante	5
1 ^{ere} butée	6
Vis d'ajustage de l'angle d'assemblage	7
2 nd butée	8
Distributeur	9
Griffes	10
Regulateur de pression des griffes	11
Manomètre	12
Témoin de presence d'air	13
Bouton de chargement des agrafes	14
Bouton de pre-serrage	15
Sectionneur d'alimentation en air	16
Manette de blocage de position interne	17
Manette de blocage de position externe	18

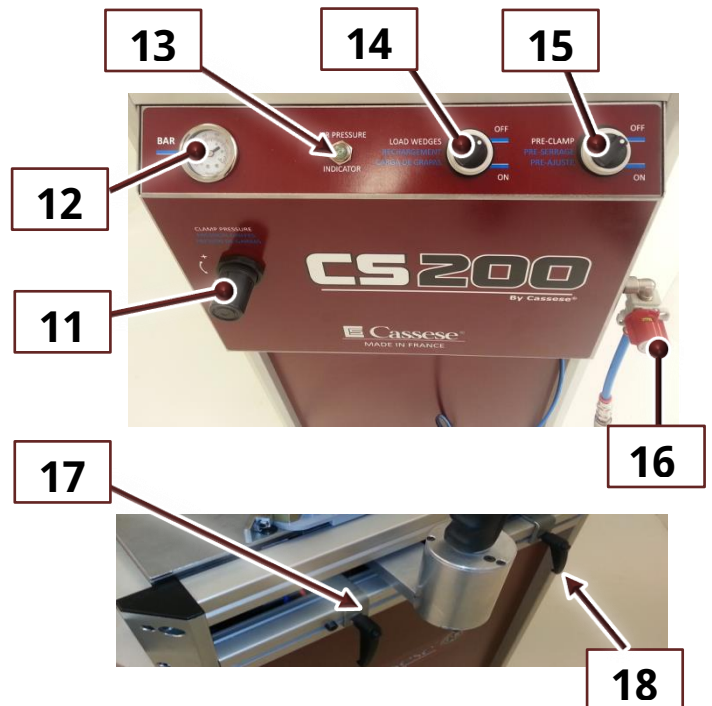

1.B INTRODUCTION

Nous vous remercions d'avoir choisi l'assembleuse CS200 CART et pour votre confiance. La CS200 CART bénéficie de tout le savoir faire de la Société Cassese. Etablie en 1976 La société Cassese est aujourd'hui reconnue dans le monde entier pour la qualité de ses produits et leur caractère innovant.

La CS200 CART vous permettra d'assembler tout type de moulure en bois, plastique ou MDF (brevet n° 7522814). L'assemblage s'opère par l'insertion d'agrafes Cassese® étudiées pour resserrer les angles de vos cadres.

1.A ACCESSOIRES FOURNIS AVEC LA MACHINE



Z26999:
1 x Presseur ajustable



Z24703:
1 x Support chevron



Z21525:
1 x Chevron assy



Z506:
1 x Marteau



Z1879:
1 x Clef Allen 2.5 mm

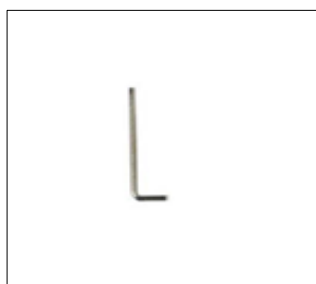

Z1882:
1 x Clef Allen 3 mm

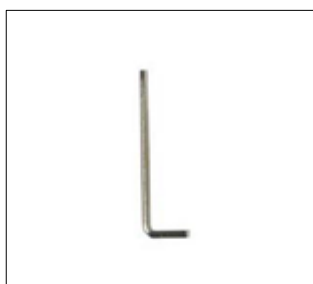

Z1884:
1 x Clef Allen 4 mm

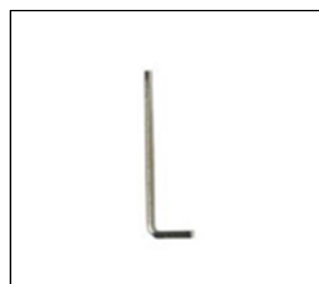

Z1885:
1 x Clef Allen 5 mm



Z3078:
Barettes d'espacement



Z1896:
1 x Tube de graisse



1 boîte d'agrafes de 7 mm bois tendre
1 boîte d'agrafes de 10mm bois tendre
1 boîte d'agrafes de 10mm bois dur.



Z535:
Outil de désenrayement d'agrafe.

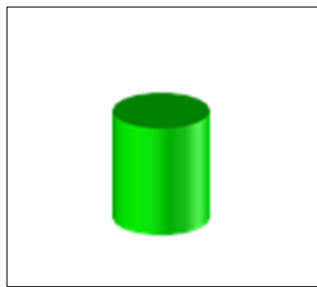

Z1791:
Elastomère vert

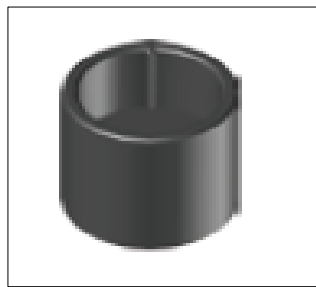

Z18065:
Support élastomère

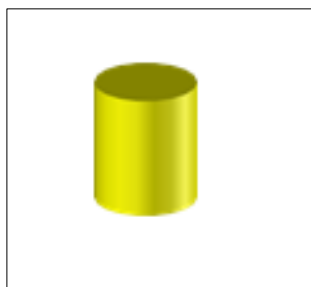

Z1783:
Elastomère jaune

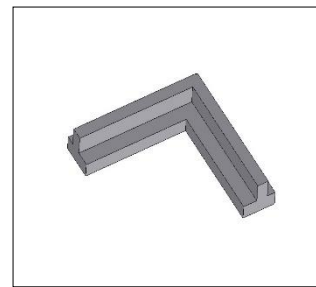

Z21524:
1 x Chevron



Z1343 (x4):
Ecrou
Z1612 (x4):
Rondelle
Z25780 (x4):
Pied réglable



Z749:
Raccord rapide



Z556:
Embout cannelé



Z701:
Embout rapide US F1/4

1.B SPECIFICATIONS TECHNIQUES

<u>Largeur moulure minimum:</u>	5mm (3/16") / hauteur minimum : 7 mm (1/4")
<u>Largeur moulure maximum:</u>	150 mm (5 29/32") / Hauteur maximum : 100 mm (4 13/32") Course maximum entre position d'agrafage (à 45°) : 190 mm (7 31/64")
<u>3 types d'agrafes :</u>	Bois tendre, bois dur & MDF. N'utilisez que des agrafes originales Cassese®. Tailles des agrafes Cassese® en chargeur: 5, 7, 10, 12 and 15 mm.
<u>Poids machine:</u>	44 kg.
<u>Dimensions :</u>	Largeur 600mm (2ft 219/64") x Longueur 589mm (1ft 113/16") x Hauteur 1171mm (3ft 107/64").
<u>Alimentation pneumatique :</u>	Air comprimé à 6-7 bars
<u>Consommation moyenne/cycle :</u>	2 NI à 6 bars (uncycle= un coin avec deux positions contenant une agrafes chacun)

1.C OPTIONS

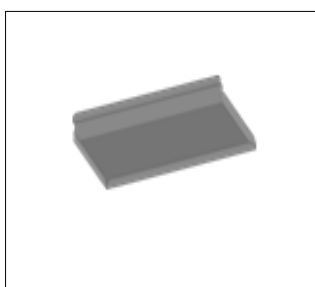

Z25147:
Support accessoire en inox

1.D GARANTIE

La présente machine est garantie un an, pièces et main d'oeuvre comprises. Les pièces d'usure* et celles endommagées suite au non respect des consignes du présent manuel sont exclues du manuel.

**Distributeur d'agrafes, chevron, presseurs élastomères et marteau sont considérés comme des pièces d'usure.*

2 MISE EN ROUTE

2.A DEBALLAGE DE LA MACHINE



Cutter
Clef plate N.13 & N.17
Clef Allen N.5

Niveau à bulle

Couper les deux bandes de transport afin de libérer le couvercle de la caisse. Avec l'aide d'une seconde personne, levez le couvercle.



Figure 2-1

Otez les 4 vis pour libérer la machine de la palette de la caisse, les vis sont visibles sous la palette.



Figure 2-2

Une fois la machine déballée, l'installer et régler ses 4 pieds. La machine doit être de niveau et les 4 pieds doivent toucher le sol afin que la machine soit stable.

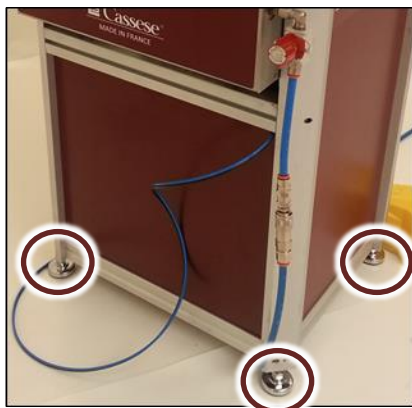

Figure 2-3



Lors de la mise à niveau de la machine, si celle-ci est installée contre une table assurez vous que le cadre ne sera soulevé par la dite table. La table et la machine doivent être de niveau.



Lors de l'installation de la machine, assurez vous que le sol est plan et pourra supporter le poids de la machine. La machine doit être installée dans un endroit sec et tempéré. Choisir un endroit où l'éclairage sera suffisant pour assurer une utilisation confortable du matériel.

2.B RACCORDS

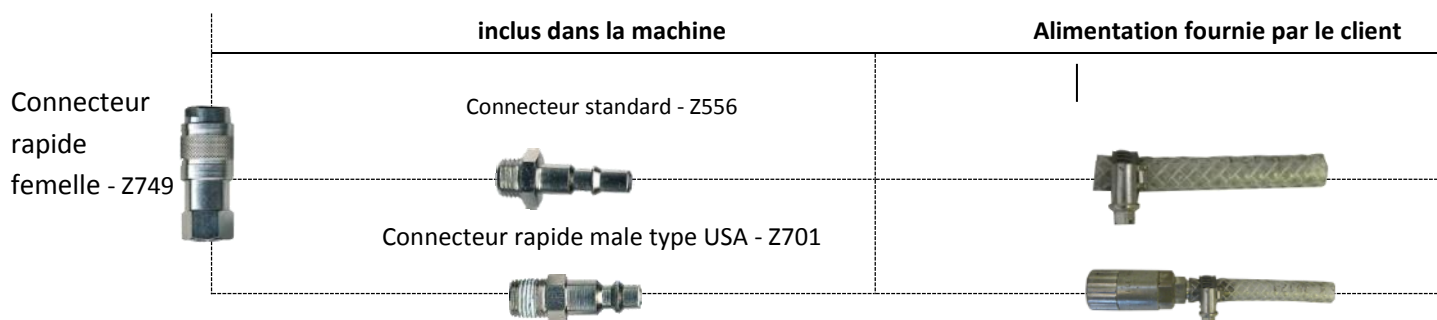

2.C RACCORDEMENT A L'AIR COMPRIMÉ

La machine doit être connectée à une source d'air comprimé fournissant entre 6 et 8bars.

Connecter la machine en utilisant les connecteurs comme spécifié chapitre II.2.B RACCORDS (page 32).

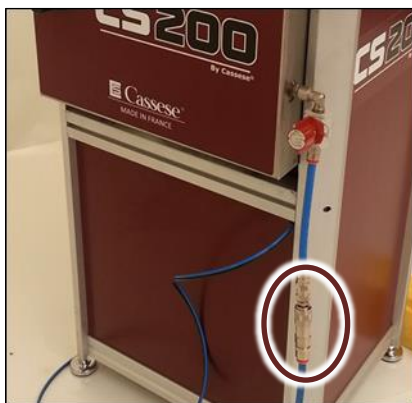

Figure 2-4

Tourner le bouton rouge pour alimenter la machine en air comprimé. Le manomètre doit montrer 6 bars (85 p.s.i.) minimum.



Figure 2-5



Le bouton rouge Figure 2-5 doit être utilisé pour mettre la machine en sécurité lors de la maintenance ou pour empêcher son utilisation. Un cadenas doit être utilisé pour le bloquer en position OFF, référez-vous au chapitre II.5.A INSTRUCTIONS RELATIVES A LA SECURITE (page 41) pour de plus amples instructions.

Si la pression indiquée sur la machine n'est pas correcte (6 bars soit 85 p.s.i.), vérifier la pression à la source (compresseur) et l'ajuster, si la pression est correcte à la source, appliquer la procédure Figure 2-6 Figure 2-7 pour l'ajuster.



Clef plate N.10

Dévisser les 2 vis ci-contre de 1 tour à l'aide de la clef plate de 10mm.

Il ne faut pas retirer ces vis.

Ouvrir le tiroir pour avoir accès au régulateur de pression d'air.



Figure 2-6

Tirer le bouton de réglage du régulateur puis le tourner pour ajuster la pression à 6 bars (85p.s.i.). Pour augmenter la pression tourner le bouton dans le sens horaire.

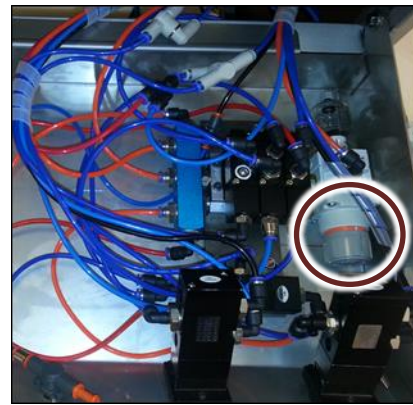

Figure 2-7

3 REGLAGES

3.A REGLAGE DE LA TABLE COULISSANTE

La table coulissante doit être ajustée pour pouvoir définir les positions d'agrafage.

Tourner le bouton de pré-serrage en position ON.



Figure 3-1

Desserrer la manette de serrage de la table.



Figure 3-2

Poser une moule sur la table comme ci-contre. Glisser la table et l'amener en contact avec la moule et les griffes.

Serrer fermement la poignée de blocage de la table pour l'immobiliser.



Figure 3-3

Tourner le bouton de pré-serrage sur OFF.



Figure 3-4

3.B REGLAGE DU PRESSEUR VERTICAL

Le presseur vertical doit être ajusté à l'aide du doigt indexable, il dispose de 7 positions.



Figure 3-5

Tirer sur le bouton noir afin d'ajuster la distance entre la partie la plus haute de la moule et le presseur. Cette distance doit être la plus courte possible et ne jamais dépasser 5cm.

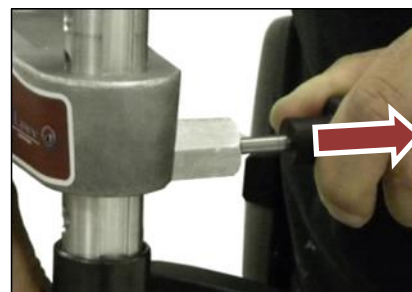

Figure 3-6



Plus courte sera la distance entre le presseur et la moule et plus rapide sera la machine. La machine n'endommagera pas la moule, même si cette distance est réduite. Si la distance entre le dessus de la moule et le presseur est supérieure à 5cm, l'agrafe ne pourra pas être correctement enfoncée.

Prendre garde à la position du presseur, le chevron doit être parallèle aux butées.

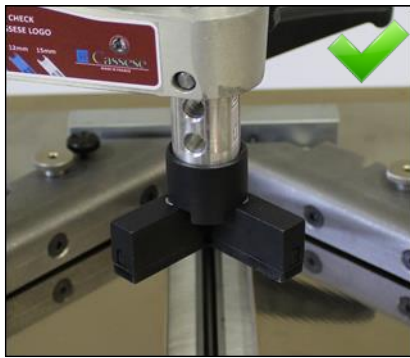

Figure 3-7

Exemple de mauvaise installation.

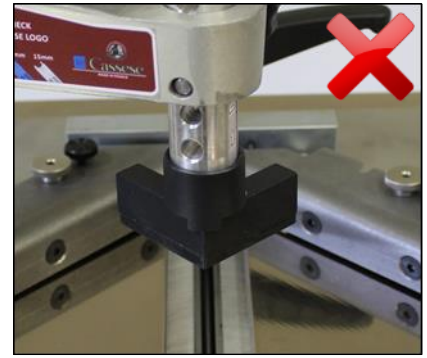

Figure 3-8

Grâce au nouveau système aimanté, il est facile de changer de type de presseur, tirer la pièce Z24703 vers le bas le remplacer.



Figure 3-9

3.C UTILISATION DU JEU DE BARRETTES

Lorsque l'on assemble des moules dont la hauteur est inférieure aux butées, il est parfois nécessaire d'utiliser les barrettes.



Figure 3-10

Exemple de mauvaise utilisation, sans les barrettes, le presseur va alors toucher les butées. La moule ne sera pas correctement maintenue et risque de sauter durant l'assemblage.



Figure 3-11

Les barrettes sont constituées de deux barres qui sont jointes par une vis et un écrou, l'écrou doit être positionné vers le bas.



Figure 3-12

Ici les barrettes sont positionnées à l'envers; l'écrou est visible sur le dessus de celles-ci.

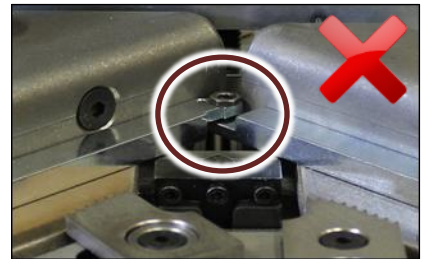

Figure 3-13

3.D SELECTION DES POSITIONS D'AGRAFAGE

La CS200 CART permet la memorisation de 2 positions qui seront ajustées à l'aide des poignées latérales, mais il est possible de positionner des agrafes entre ces deux positions extrêmes. Il est possible d'empiler des agrafes en toute position.

3.ETROIS REGLES ESSENTIELLES POUR L'ASSEMBLAGE

- 1- Un MINIMUM de 2 mm d'espace (moins de 1/8 de pouce) doit être respecté au-dessus des agrafes.
- 2- Des agrafes de même hauteur peuvent être empilées afin d'assembler des moulures de hauteurs différentes.
- 3- Les agrafes doivent être alignées avec les points les plus hauts des moulures.

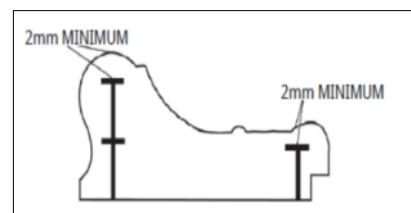

Figure 3-14



Lors de la selection des positions d'agrafage, s'assurer que le presseur vertical sera bien aligné sur une surface plane.

3.FREGLAGE DE L'ANGLE D'ASSEMBLAGE

Si le coin est ouvert côté extérieur au cadre.

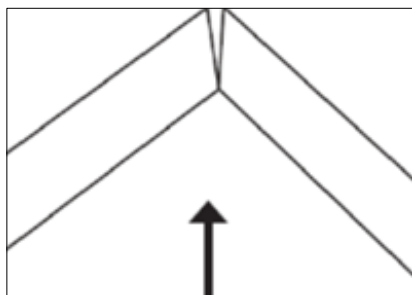

Figure 3-15

Serrer la vis ci-contre.

Vérifier à nouveau la qualité de l'angle d'assemblage, recommencer si nécessaire.

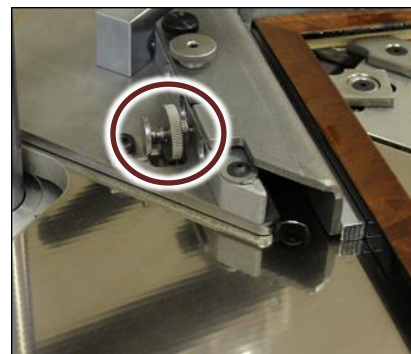

Figure 3-16

Si le coin est ouvert côté intérieur du cadre.

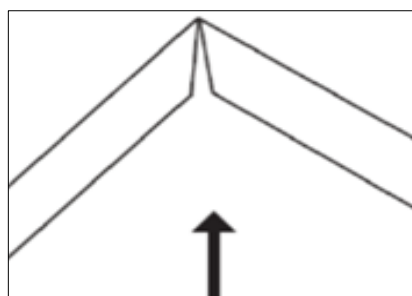

Figure 3-17

Desserrer la vis ci-contre.

Vérifier à nouveau la qualité de l'angle d'assemblage, recommencer si nécessaire.



Figure 3-18

Si vous obtenez ce résultat en fin d'assemblage, l'angle d'assemblage n'est pas à 45°.

Votre scie est probablement dérégulée, se référer à son manuel d'instructions afin de remédier au problème.

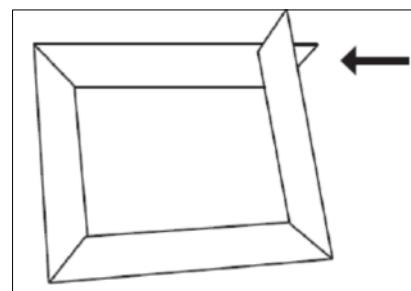

Figure 3-19

3.G MOYEN D'ASSEMBLAGE

Grâce au code de couleur, il est facile d'identifier les agrafes nécessaires à l'assemblage. Un poussoir jaune permet de repérer des agrafes pour les bois durs, tandis qu'un poussoir blanc indiquera des agrafes pour bois normal.

Des agrafes spéciales pour le MDF (ou les bois très durs) sont également disponibles, elles sont identifiées par un poussoir rouge dans le chargeur. Contactez votre distributeur Cassese pour les obtenir.

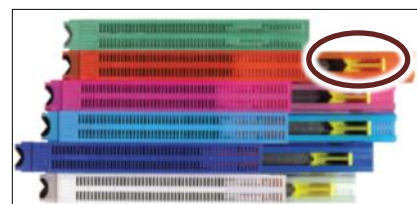

Figure 3-20

	BOÎTE DE 6 CHARGEURS		BOÎTE DE 40 CHARGEURS		
	BOIS TENDRE	BOIS DUR	BOIS TENDRE	BOIS DUR	MDF
agrafes 15 mm	30315NC01	31315BDC0	30415NC01	31415BDC0	31415MDF
agrafes 12 mm	30312NC01	31312BDC0	30412NC01	31412BDC0	31412MDF
agrafes 10 mm	30310NC01	31310BDC0	30410NC01	31410BDC0	31410MDF
agrafes 7 mm	30307NC01	31307BDC0	30407NC01	31407BDC0	31407MDF
agrafes 5 mm	30305NC01	31305BDC0	30405NC01	31405BDC0	
agrafes 3 mm	30303NC01		30403NC01		



Il est recommandé d'utiliser les agrafes adaptées au bois à assembler, l'utilisation d'agrafes bois dur dans un bois tendre engendrera un moindre rapprochement des moulures. Une première indication consiste à tenter de griffer le dessous de la moulure avec les ongles, si c'est impossible, on utilisera alors les agrafes bois dur, sinon on utilisera des agrafes bois normal.

3.H CHARGEMENT DES AGRAFES

Pour recharger la machine tourner le bouton de chargement en position ON.

Le pousse agrafe va alors reculer pour vous permettre le chargement.



Figure 3-21

Introduire le chargeur et tourner le bouton en position OFF.

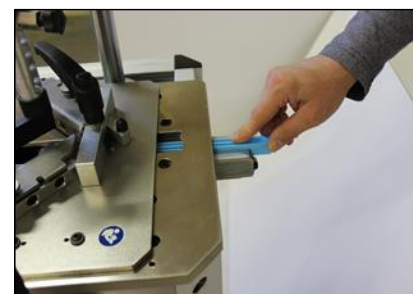

Figure 3-22

3.I CHANGER DE TAILLE D'AGRAFES

Répéter la procédure Figure 3-21, introduisez alors un chargeur de la taille voulue, grâce au système de chargeur, aucun réglage n'est nécessaire.

Tourner ensuite le bouton de chargement en position **OFF**.

3.J REGLAGE DES POSITIONS D'AGRAFAGE

Après avoir procédé aux réglages du chapitre 3 REGLAGES. Suivre la procédure qui suit:

Poser une seule moulure sur la table comme dans l'image ci-contre. Ceci permettra une bonne visualisation des positions d'assemblage.

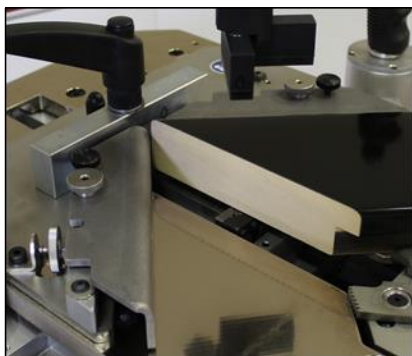

Figure 3-23

Tourner le bouton de pré-serrage sur ON.



Figure 3-24

Tourner le joystick et déplacer la tête de distribution à la position de l'agrafe la plus à l'intérieur du cadre. Relâcher le joystick.

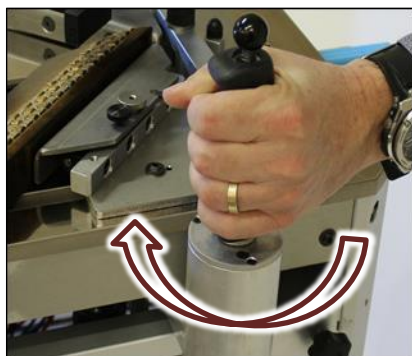

Figure 3-25

Desserrer la poignée de la butée de blocage de la position interne.

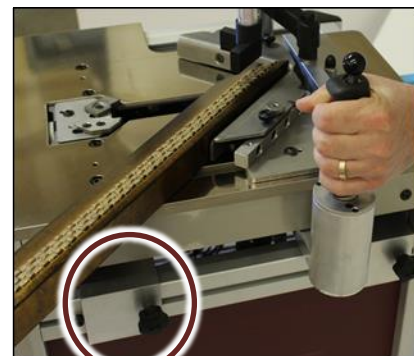

Figure 3-26

Bouger la butée jusqu'au contact du support du Joystick, puis verrouiller à nouveau la poignée.

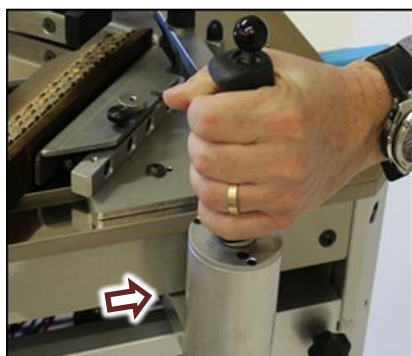

Figure 3-27

Tourner le joystick et déplacer la tête de distribution à la position de l'agrafe le plus à l'extérieur du cadre.
Relâcher le joystick.

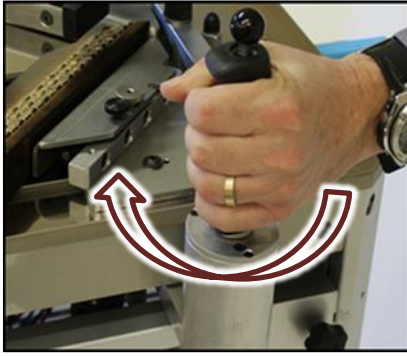

Figure 3-28

Desserrer la poignée de blocage de la butée de la position extérieure.

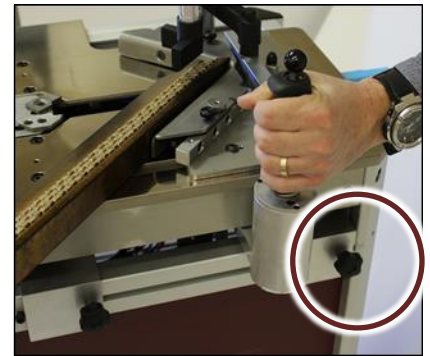

Figure 3-29

Bouger la butée jusqu'au contact avec le support du joystick.

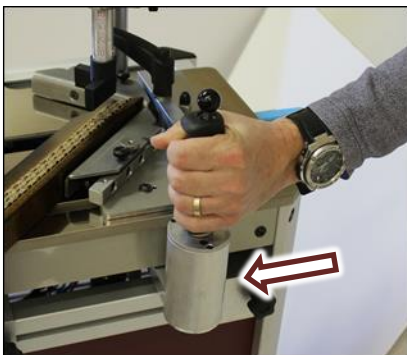

Figure 3-30

Tourner le bouton de pré-serrage en position OFF.



Figure 3-31

4 ASSEMBLAGE DU CADRE

Poser la moulure droite contre la butée et la pousser jusqu'au contact avec la seconde butée. Poser la seconde moulure sur la table et la ramener contre la première moulure.

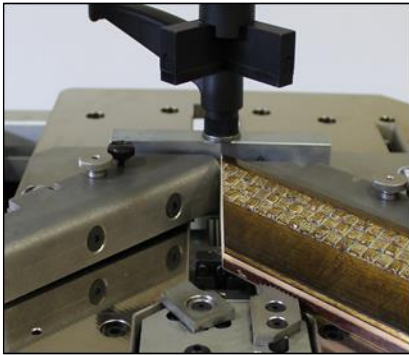

Figure 4-1

Tourner le Joystick et l'amener à la position voulue. L'assemblage peut être fait en commençant par la position interne ou externe.

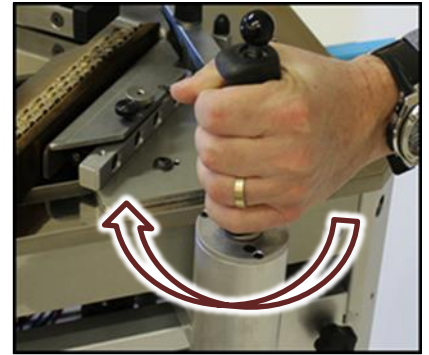

Figure 4-2

Appuyer sur la pédale pour obtenir le serrage des moulures.



Figure 4-3

Appuyer sur le bouton pour tirer une première agrafe.

Conserver le bouton enfoncé jusqu'à ce que la machine relâche la pression sur la moulure.

Appuyer une seconde fois sur le bouton si une autre agrafe doit être empilée sur cette position. Maintenir la pédale enfoncée pendant toute cette procédure.



Figure 4-4

Tourner le joystick pour passer à une autre position.



Figure 4-5

En maintenant la pédale enfoncée, appuyer sur le bouton du joystick pour tirer l'agrafe.

Conserver le bouton enfoncé jusqu'à ce que la machine relâche la pression sur la moulure. Appuyer une seconde fois sur le bouton si une autre agrafe doit être empilée sur cette position.



Figure 4-6

Relâcher la pédale lorsque l'assemblage est terminé. Il est possible de tirer des agrafes entre les deux positions extrêmes, l'empilage est possible même entre ces deux butées.

5 MAINTENANCE

5.A INSTRUCTIONS RELATIVES A LA SECURITE



La CS200 cart utilise une alimentation pneumatique. Il est essentiel de s'assurer qu'elle est bien déconnectée avant d'effectuer toute maintenance. Suivre les instructions ci-dessous afin de garantir votre sécurité.

Tourner le bouton rouge en position EXH.

Débrancher la machine du circuit pneumatique.

Installer un cadenas sur la vanne afin d'interdire la remise sous pression du circuit pendant tout le temps de la maintenance.



Figure 5-1



Si vous utilisez de l'air comprimé pour nettoyer des pièces, portez des lunettes de protection. Il vous est même recommandé de préférer l'utilisation de l'aspirateur, moins nocif car il ne soulèvera pas la poussière. La maintenance doit être accomplie par du personnel formé et compétent

5.B PROGRAMME DE MAINTENANCE

5.B.a Maintenance quotidienne:

Il est recommandé de nettoyer chaque jours les tables de la machine avec un chiffon doux et de s'assurer qu'il n'y a pas de débris ni de colle dans la tête de distribution. Si besoin suivre les procédures II.5.C DEMONTAGE DE LA TETE DE DISTRIBUTION (page 42) et II.5.D LUBRIFICATION DE LA TETE DE DISTRIBUTION (page 43) afin de nettoyer la tête de distribution de la machine. Il est important de ne pas laisser de la colle sécher dans la tête car celle-ci va empêcher le bon positionnement du chargeur d'agrafes.

5.B.b Maintenance préventive:

Un fois par semaine, il convient de procéder aux opérations suivantes afin de nettoyer et de lubrifier la tête de distribution de la machine :

II.5.A INSTRUCTIONS RELATIVES A LA SECURITE (page 41)

II.5.C DEMONTAGE DE LA TETE DE DISTRIBUTION (page 42)

II.5.D LUBRIFICATION DE LA TETE DE DISTRIBUTION (page 43)

5.B.c Tous les six mois:

Tous les six mois, une maintenance plus approfondie doit être effectuée, procéder aux opérations suivantes afin de garantir un bon fonctionnement de la machine

- II.5.A INSTRUCTIONS RELATIVES A LA SECURITE (page 41)
- II.5.C DEMONTAGE DE LA TETE DE DISTRIBUTION (page 42)
- II.5.D LUBRIFICATION DE LA TETE DE DISTRIBUTION (page 43)
- II.5.F OUVERTURE DU PANNEAU LATÉRAL (page 44)
- II.5.G LUBRIFICATION DES COLONNES HORIZONTALES (page 44)
- II.5.H VERIFICATION DES SECURITES DE LA MACHINE (page 45)

5.C DEMONTAGE DE LA TETE DE DISTRIBUTION

Démonter régulièrement la tête de distribution de la machine afin de procéder à son entretien. Suivre la procédure qui suit :



Clef Allen N.2,5

Tourner le bouton de chargement des agrafes en position ON.

Le pousse agrafe va reculer pour vous permettre de retirer le chargeur présent.



Figure 5-2

Oter le chargeur

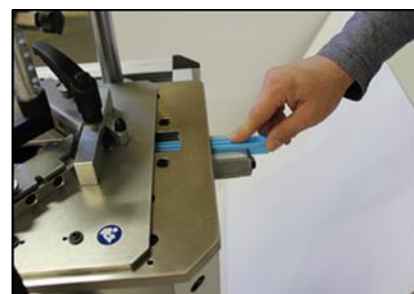

Figure 5-3

A l'aide la clef Allen de 2.5mm dévisser la vis de retenu de la tête de ½ tours.



Figure 5-4

Tirer sur la tête afin de l'extraire de la machine.



Figure 5-5

5.D LUBRIFICATION DE LA TETE DE DISTRIBUTION



Clef Allen N.5
Tube de graisse, référence Cassese:Z1896

Spray lubrifiant type WD40.

Oter toutes les vis de la tête de distribution.



Figure 5-6

Séparer les plaques de la tête et les nettoyer à l'aide d'un chiffon ainsi que d'un spray lubrifiant. Ceci fait, réassembler la tête, les deux plus petites vis sont destinées au petit guide carré qui est à l'intérieur de la tête.

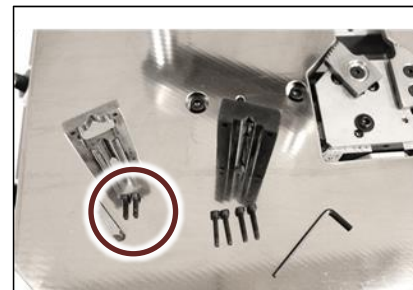

Figure 5-7

Insérer l'équivalent d'une noisette de graisse.



Figure 5-8

5.E DEBLOCAGE DE LA MACHINE



Outils ôte agrafe référence Cassese : Z535

Une agrafe peut parfois rester coincée en position haute dans la tête.



Figure 5-9

Utiliser l'outil fourni dans la boîte d'accessoires afin de dégager cette agrafe. L'introduire de 6mm dans la tête de distribution puis retirer l'outil. Il doit alors être possible de dégager le chargeur d'agrafes.



Figure 5-10

S'il n'est pas possible de pousser l'agrafe vers le bas, celle-ci est sans doute tordue ou coincée. Poser vos deux mains à plat sur la potence et donner un choc vers le bas. Un claquement doit se faire entendre indiquant que le marteau est maintenant décroché. Suivre la procédure II.5.C DEMONTAGE DE LA TETE DE DISTRIBUTION (page 42) Afin de démonter le bloc de distribution et débloquer la machine. Si le bloc ne peut être extrait, tenter à nouveau de mettre un choc vers le bas sur la potence pour débloquer le marteau.

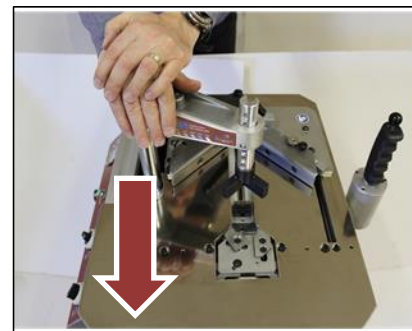

Figure 5-11



Ne poussez jamais sur une agrafes avec les doigts, elles sont très affûtées!!!

5.FOUVERTURE DU PANNEAU LATERAL



Clef plate N.10

Afin d'avoir accès aux parties mécaniques de la machine, il est impératif d'ouvrir le panneau latéral de la machine.

Tenir d'une main le haut du panneau.

Avec la clef plate N.10 desserrer de 1 tour les 2 vis de chaque coté du panneau. Ne pas démonter ces vis.

Ouvrir le panneau.



Figure 5-12

5.G LUBRIFICATION DES COLONNES HORIZONTALES



Clef plate N.10
Chiffon ainsi qu'un lubrifiant type WD40
Huile moteur

Pour votre sécurité suivre Les recommandations II.5.A INSTRUCTIONS RELATIVES A LA SECURITE (page 41).

Oter le panneau latéral comme indiqué dans la procédure II.5.F OUVERTURE DU PANNEAU LATERAL (page 44) .

Vaporiser du spray lubrifiant sur les colonnes puis les nettoyer à l'aide d'un chiffon. Appliquer ensuite de l'huile sur ces deux colonnes.

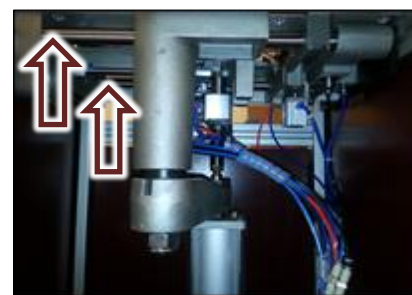

Figure 5-13

5.H VERIFICATION DES SECURITES DE LA MACHINE

Pour votre sécurité, ôter les moulures de la table de la machine, ne posez pas vos mains sur la table durant cet essai.

Appuyer sur la pédale et vérifier que les griffes avancent puis reculent immédiatement lorsque la pédale est relâchée. .

Si ce n'est pas le cas, contacter votre distributeur Cassese.



Figure 5-14

Pour votre sécurité, ôter les moulures de la table de la machine, ne posez pas vos mains sur la table durant cet essai.

Ôter le chargeur d'agrafes, se référer au chapitre II.3.I CHANGER DE TAILLE D'AGRAFES (page 38).

Presser la pédale et la maintenir enfoncée. Appuyer sur le bouton, la machine ne devrait pas tirer en l'absence de moulure. Si la machine tente un assemblage malgré tout, contacter votre distributeur Cassese afin de rétablir la sécurité.



Figure 5-15



En cas de problème, il est possible de relâcher la pédale ou le bouton d'agrafage pour interrompre la séquence d'agrafage. Si une agrafe est engagée dans le distributeur, suivre la procédure II.5.EDEBLOCAGE DE LA MACHINE (page 43) pour ôter cette agrafe.



Assurez vous que la machine est complète et que tous les panneaux sont en place. En cas de pièce manquante, utiliser les vues éclatées du présent manuel afin de les identifier. Contacter votre distributeur Cassese afin de les commander. Un panneau manquant peut exposer l'opérateur à un risque d'accident.

5.I GUIDE DE DEPANNAGE

Si votre machine ne semble pas fonctionner correctement, se reporter à la rubrique ci-dessous. Si le problème ne peut être corrigé, contacter votre distributeur Cassese ou vous rendre sur le site: www.cassese.com.

Les agrafes ne sortent pas de la machine:

- > Le chargeur est vide.
- > Il y a de la saleté dans le bloc distributeur ce qui empêche les agrafes d'y pénétrer. Suivre les procédures :

II.5.A INSTRUCTIONS RELATIVES A LA SECURITE (page 41)

II.5.C DEMONTAGE DE LA TETE DE DISTRIBUTION (page 42)

II.5.D LUBRIFICATION DE LA TETE DE DISTRIBUTION (page 43)

- > Le marteau est cassé, suivre les procédures :

II.5.A INSTRUCTIONS RELATIVES A LA SECURITE (page 41)

II.5.C DEMONTAGE DE LA TETE DE DISTRIBUTION (page 42)

II.5.D LUBRIFICATION DE LA TETE DE DISTRIBUTION (page 43)

Les agrafes ne pénètrent pas totalement dans la mouleure:

- > La pédale ou le bouton sont relâchés trop tôt, les maintenir enfoncés jusqu'à ce que le presseur remonte automatiquement.
- > La mouleure est trop étroite; le presseur touche les butées. Se reporter au chapitre 3.C UTILISATION DU JEU DE BARRETTES (page 35).
- > Vérifier la pression d'air du compresseur et de la machine. Se reporter au chapitre 2.C RACCORDEMENT A L'AIR COMPRIMÉ (page 32) pour procéder au réglage.
- > La distance entre le presseur et la mouleure est trop grande, se reporter au chapitre 3.B REGLAGE DU PRESSEUR VERTICAL (page 34)
- > Essayer d'utiliser un presseur plus dur (chevron ou élastomère vert)
- > Le marteau est endommagé, démonter le bloc distributeur pour le contrôler, suivre les procédures ci-dessous pour le démontage :

II.5.A INSTRUCTIONS RELATIVES A LA SECURITE (page 41)

II.5.C DEMONTAGE DE LA TETE DE DISTRIBUTION (page 42)

- > Le capteur fin de course doit être réglé : contacter votre distributeur Cassese pour obtenir de l'aide.

L'agrafe se casse dans le bois:

- > Essayer des agrafes bois dur ou MDF.

Les griffes fonctionnent mais le presseur vertical ne fonctionne pas:

- > Les griffes sont trop loin de la mouleure, se reporter aux instructions du chapitre 3.A REGLAGE DE LA TABLE COULISSANTE (page 34). Une sécurité empêche la machine de tirer une agrafe si les mouleures ne sont pas détectées. Il faut donc veiller au bon réglage de la table et en serrer fermement la manette de blocage.

Le distributeur est plein de graisse, les mouleures sont tâchées:

- > Suivre les procédures suivantes pour démonter le bloc de distribution et ôter l'excès de graisse :

II.5.A INSTRUCTIONS RELATIVES A LA SECURITE (page 41)

II.5.C DEMONTAGE DE LA TETE DE DISTRIBUTION (page 42)

Faire des essais dans des chutes avant de reprendre votre production.

Inserer/oter les mouleures est difficile:

- > Les griffes horizontales sont trop proches de la mouleure: se reporter aux instructions du chapitre 3.A REGLAGE DE LA TABLE COULISSANTE (page 34).

Les angles sont décalés:

- > Assurez-vous de toujours insérer la mouleure contre la butée numéro 6 (voir page 27) en premier et de bien l'amener en butée contre la butée opposée.

III. EXPLODED VIEWS/ VUE ECLATEES

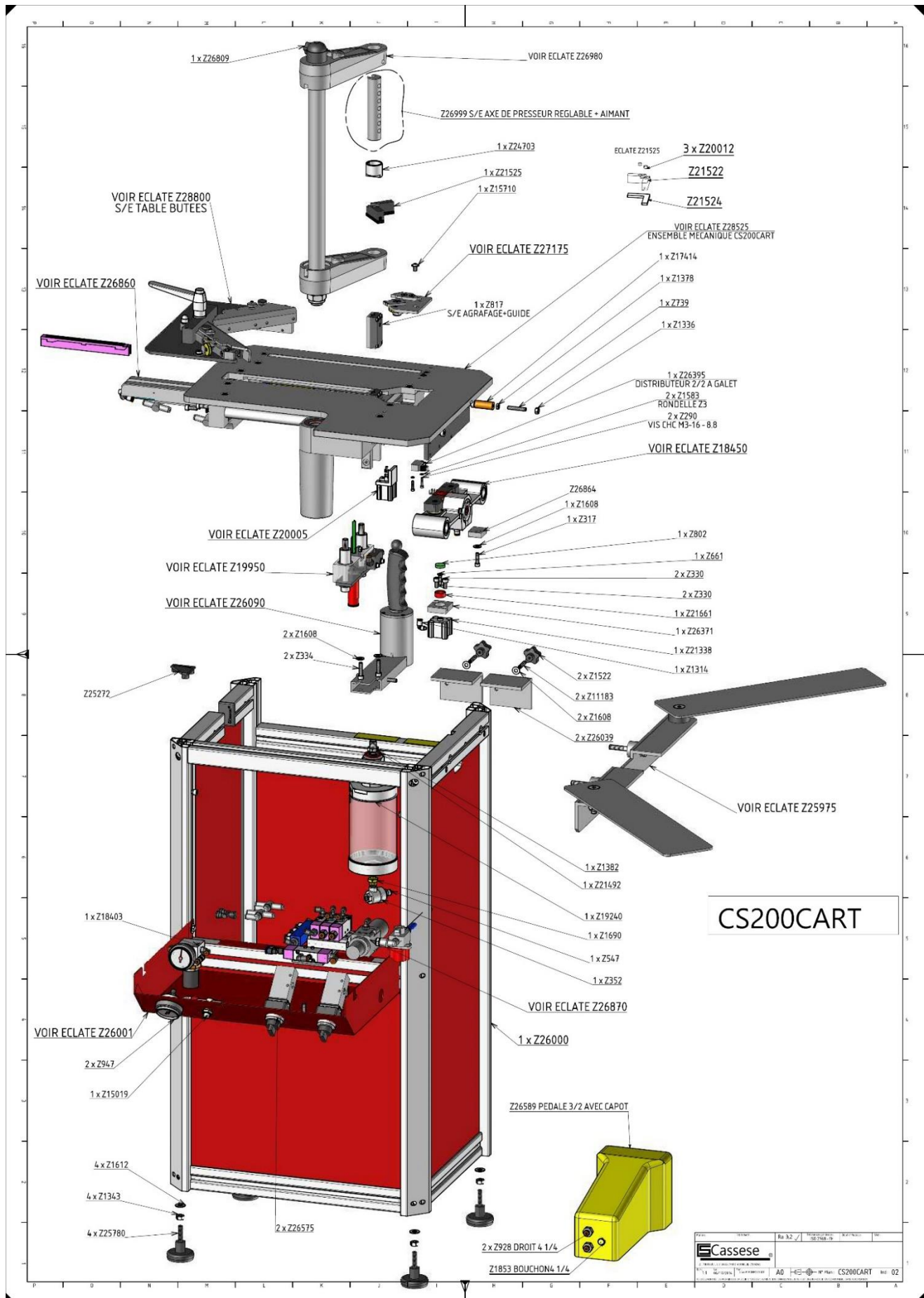

CS200CART

Cassese		Rev. 3.2	10/14/09	01
Cassese		AD	CS200CART	02

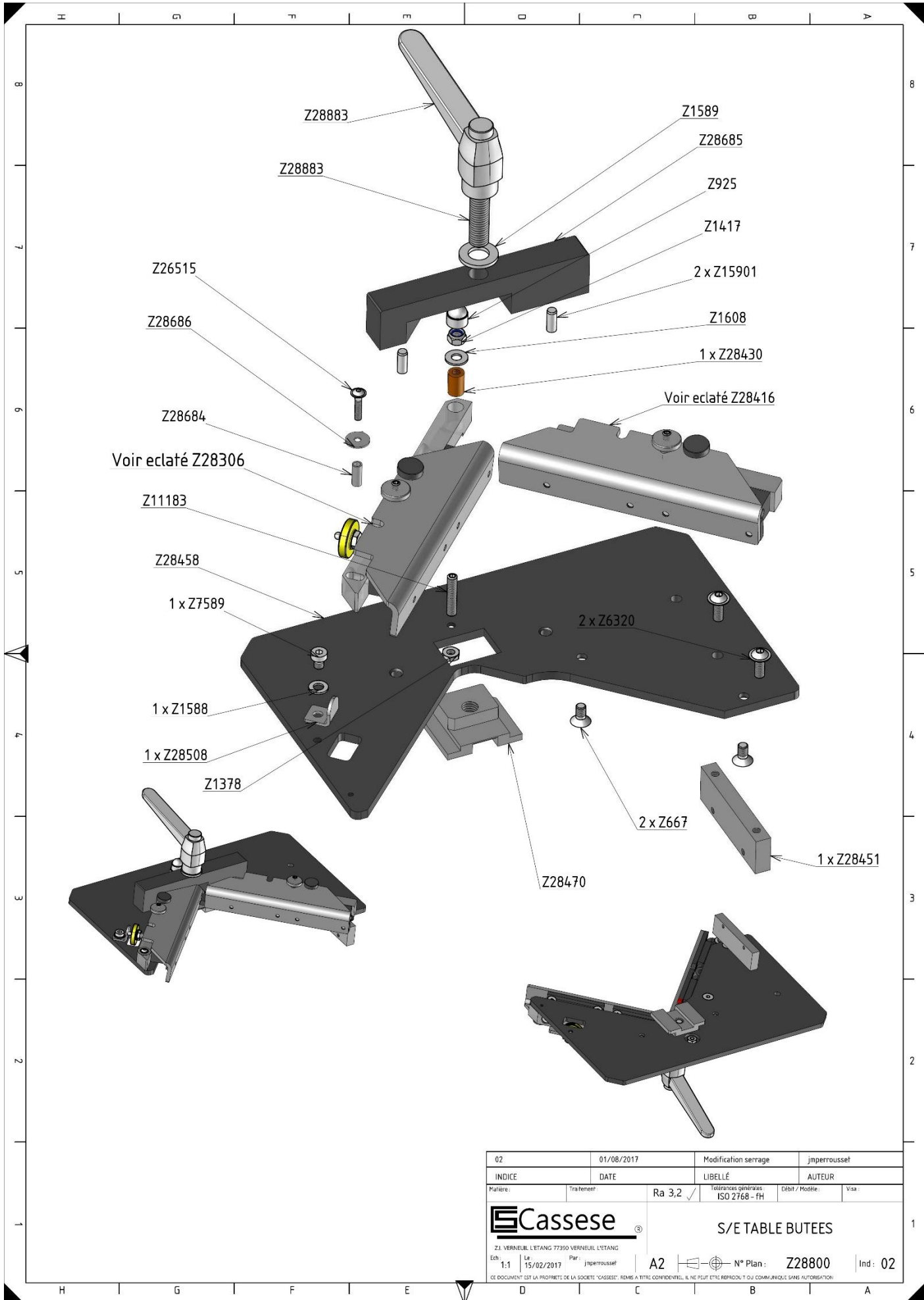

02	01/08/2017	Modification serrage	jimperrouset
INDICE	DATE	LIBELLÉ	AUTEUR
Matière:	Tratament:	Ra 3,2 ✓	Tolérances générales: ISO 2768 - FH
		Debit / Modèle:	Visa:
		S/E TABLE BUTEES	
Z1 VERNEUIL L'ETANG 77300 VERNEUIL L'ETANG			
Ech: 1:1	Le: 15/02/2017	Par: jimperrouset	A2
CE DOCUMENT EST LA PROPRIETE DE LA SOCIETE 'CASSESE'. DEMIS A TITRE CONFIDENTIEL. IL NE PEUT ETRE REPRODUIT OU COMMUNIQUÉ SANS AUTORISATION		N° Plan: Z28800	Ind: 02

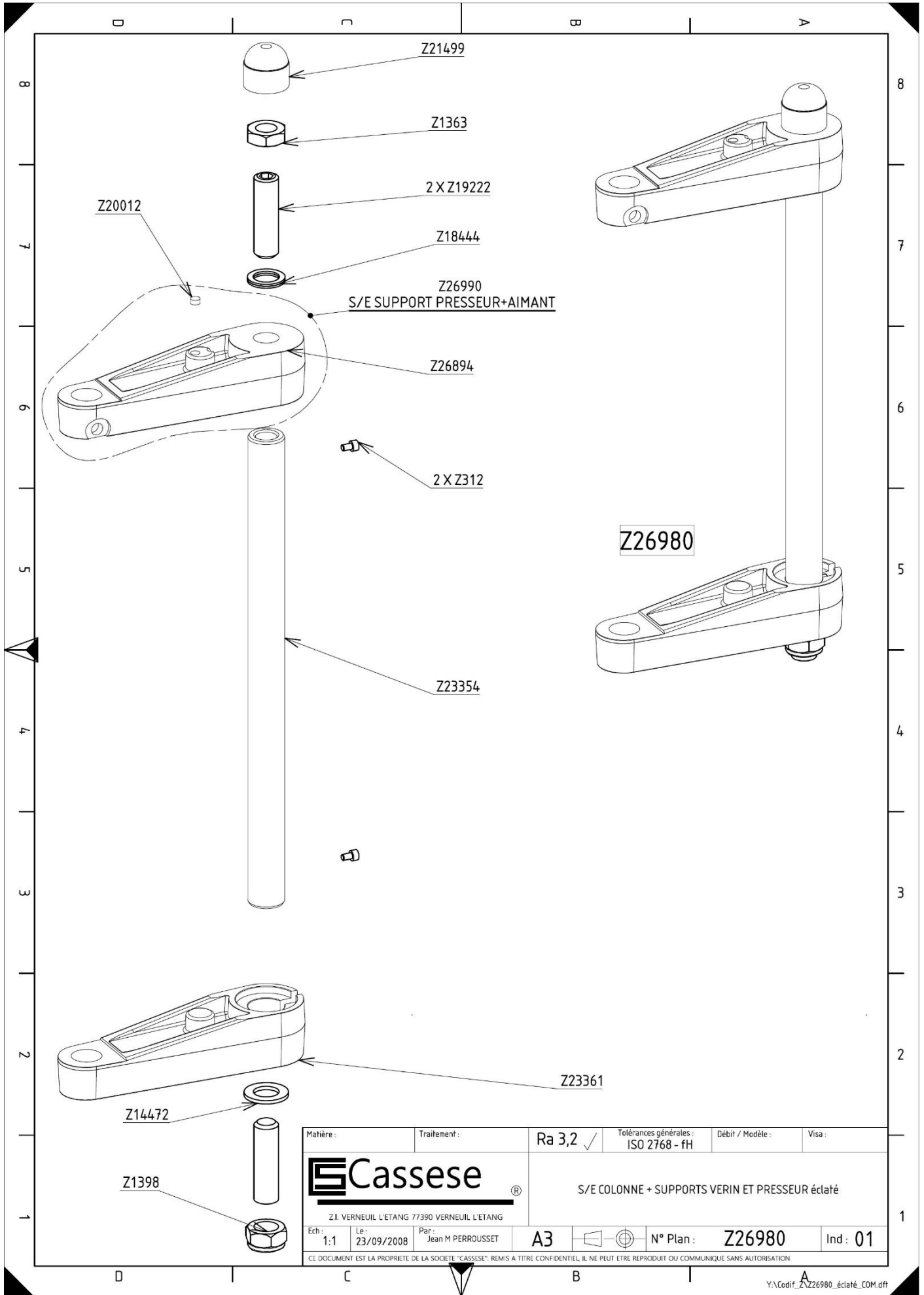

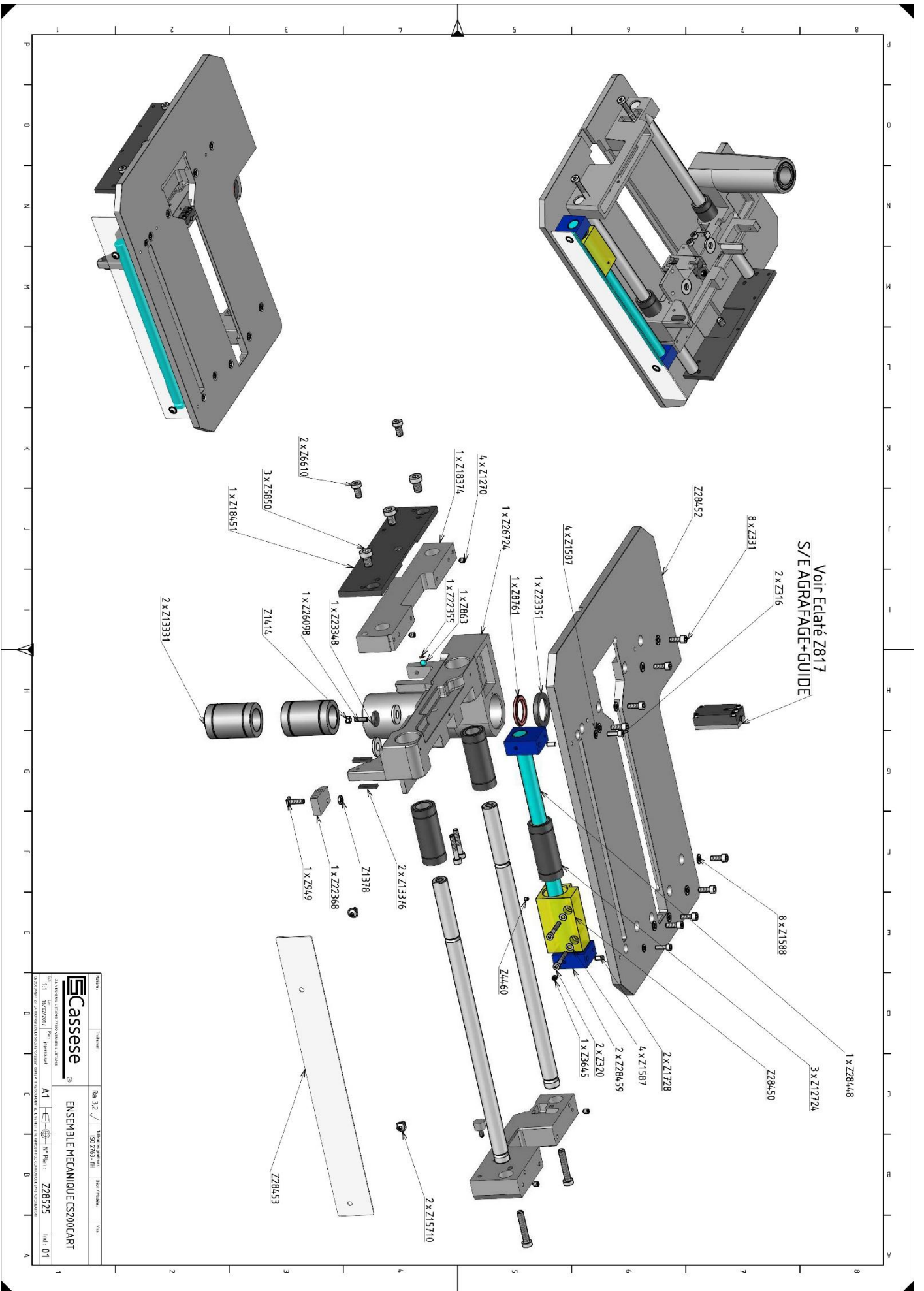

		Référence: RA 3.2 / 1507286.01	
Z1507286.01		Part Name: 1507286.01	
Ensemble mécanique CS200CART		1507286.01	
11 1507286.01		1507286.01	
A1		Z28525	
01		01	

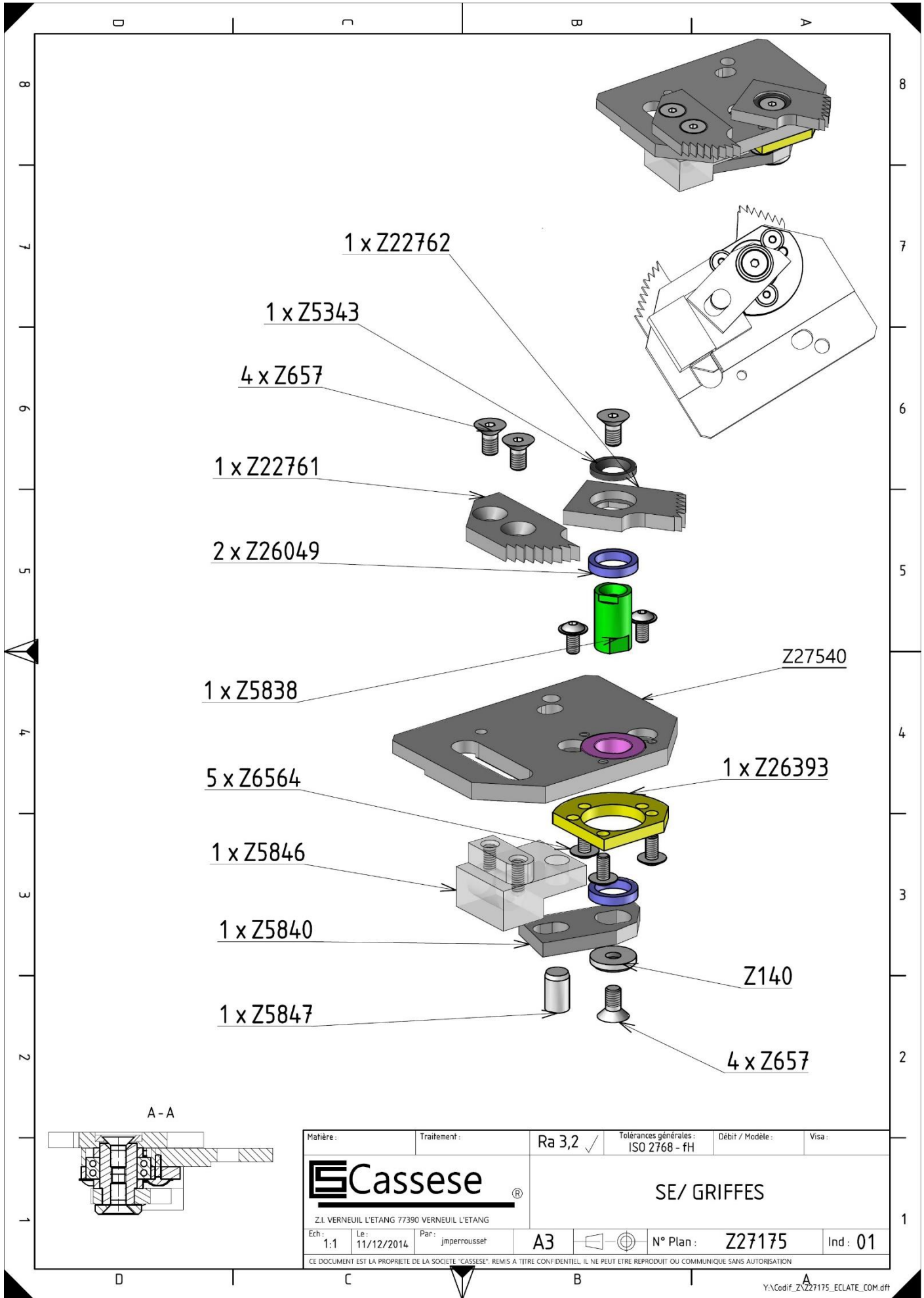

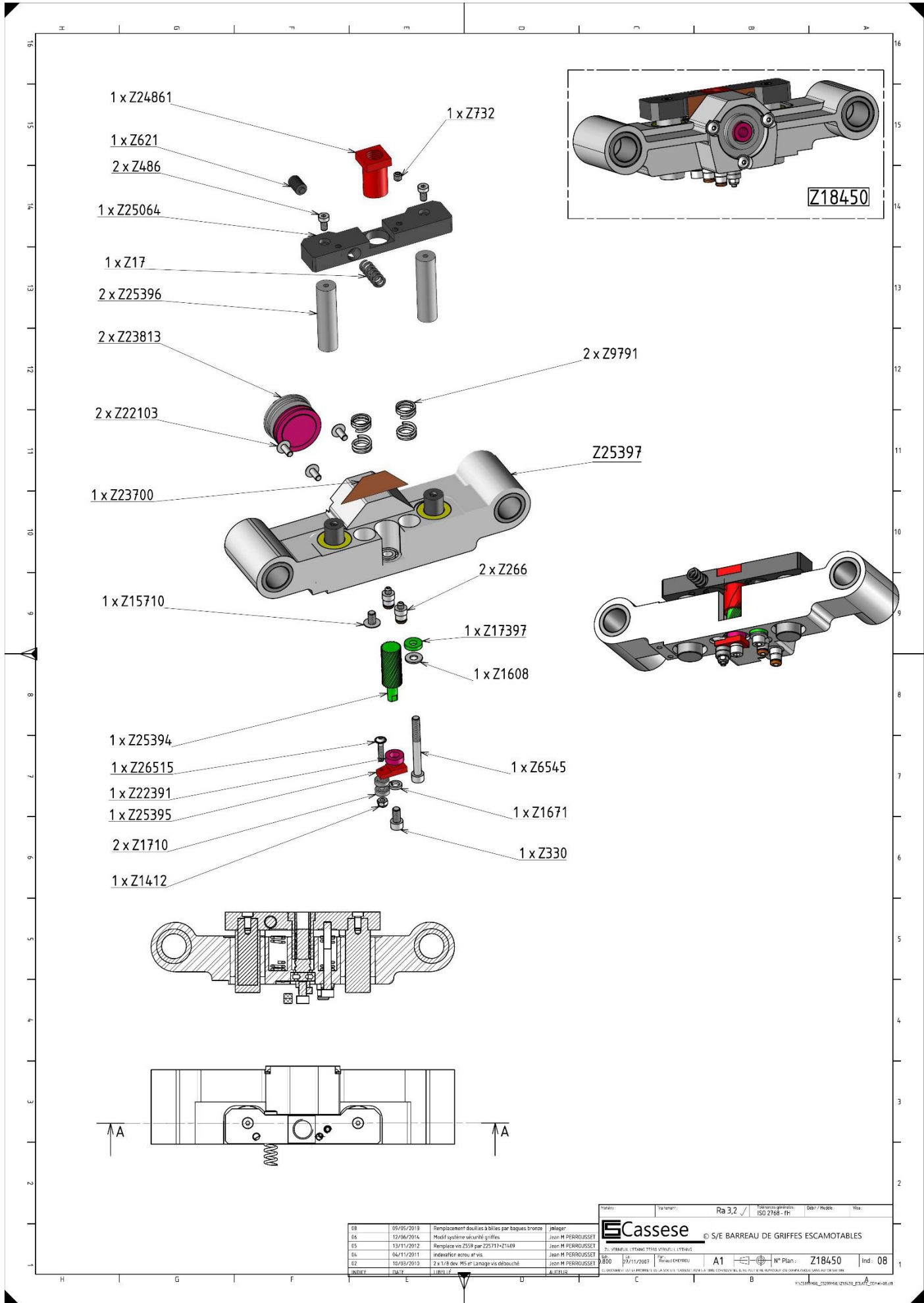

08	05/05/2013	Remplacemnt douilles à billes par bagues brosse	Jallegre
05	12/06/2014	Modif système sécurité griffes	Jean M PERROUSSET
05	13/11/2012	Remplace vis Z59 par Z2713+Z1409	Jean M PERROUSSET
04	04/11/2011	indexation etou. et vis	Jean M PERROUSSET
02	10/03/2010	2 x 1/8 dex M5 et Lavage vis débouché	Jean M PERROUSSET
INDI	JALP	JURIF	ALEFIS

Matière: Traitement: Ra 3,2 ✓ Référence graphique: ISO 2768 - TH Dens / Module Vis:

Cassese © S/E BARREAU DE GRIFFES ESCAMOTABLES

2D: 08000111 (1) (2) (3) (4) (5) (6) (7) (8) (9) (10) (11) (12) (13) (14) (15) (16) (17) (18) (19) (20) (21) (22) (23) (24) (25) (26) (27) (28) (29) (30) (31) (32) (33) (34) (35) (36) (37) (38) (39) (40) (41) (42) (43) (44) (45) (46) (47) (48) (49) (50) (51) (52) (53) (54) (55) (56) (57) (58) (59) (60) (61) (62) (63) (64) (65) (66) (67) (68) (69) (70) (71) (72) (73) (74) (75) (76) (77) (78) (79) (80) (81) (82) (83) (84) (85) (86) (87) (88) (89) (90) (91) (92) (93) (94) (95) (96) (97) (98) (99) (100)

0800 27/11/2007 A1 N° Plan: Z18450 Ind: 08

1100000001 - 1100000002 - 1100000003 - 1100000004 - 1100000005 - 1100000006 - 1100000007 - 1100000008 - 1100000009 - 1100000010 - 1100000011 - 1100000012 - 1100000013 - 1100000014 - 1100000015 - 1100000016 - 1100000017 - 1100000018 - 1100000019 - 1100000020 - 1100000021 - 1100000022 - 1100000023 - 1100000024 - 1100000025 - 1100000026 - 1100000027 - 1100000028 - 1100000029 - 1100000030 - 1100000031 - 1100000032 - 1100000033 - 1100000034 - 1100000035 - 1100000036 - 1100000037 - 1100000038 - 1100000039 - 1100000040 - 1100000041 - 1100000042 - 1100000043 - 1100000044 - 1100000045 - 1100000046 - 1100000047 - 1100000048 - 1100000049 - 1100000050 - 1100000051 - 1100000052 - 1100000053 - 1100000054 - 1100000055 - 1100000056 - 1100000057 - 1100000058 - 1100000059 - 1100000060 - 1100000061 - 1100000062 - 1100000063 - 1100000064 - 1100000065 - 1100000066 - 1100000067 - 1100000068 - 1100000069 - 1100000070 - 1100000071 - 1100000072 - 1100000073 - 1100000074 - 1100000075 - 1100000076 - 1100000077 - 1100000078 - 1100000079 - 1100000080 - 1100000081 - 1100000082 - 1100000083 - 1100000084 - 1100000085 - 1100000086 - 1100000087 - 1100000088 - 1100000089 - 1100000090 - 1100000091 - 1100000092 - 1100000093 - 1100000094 - 1100000095 - 1100000096 - 1100000097 - 1100000098 - 1100000099 - 1100000100

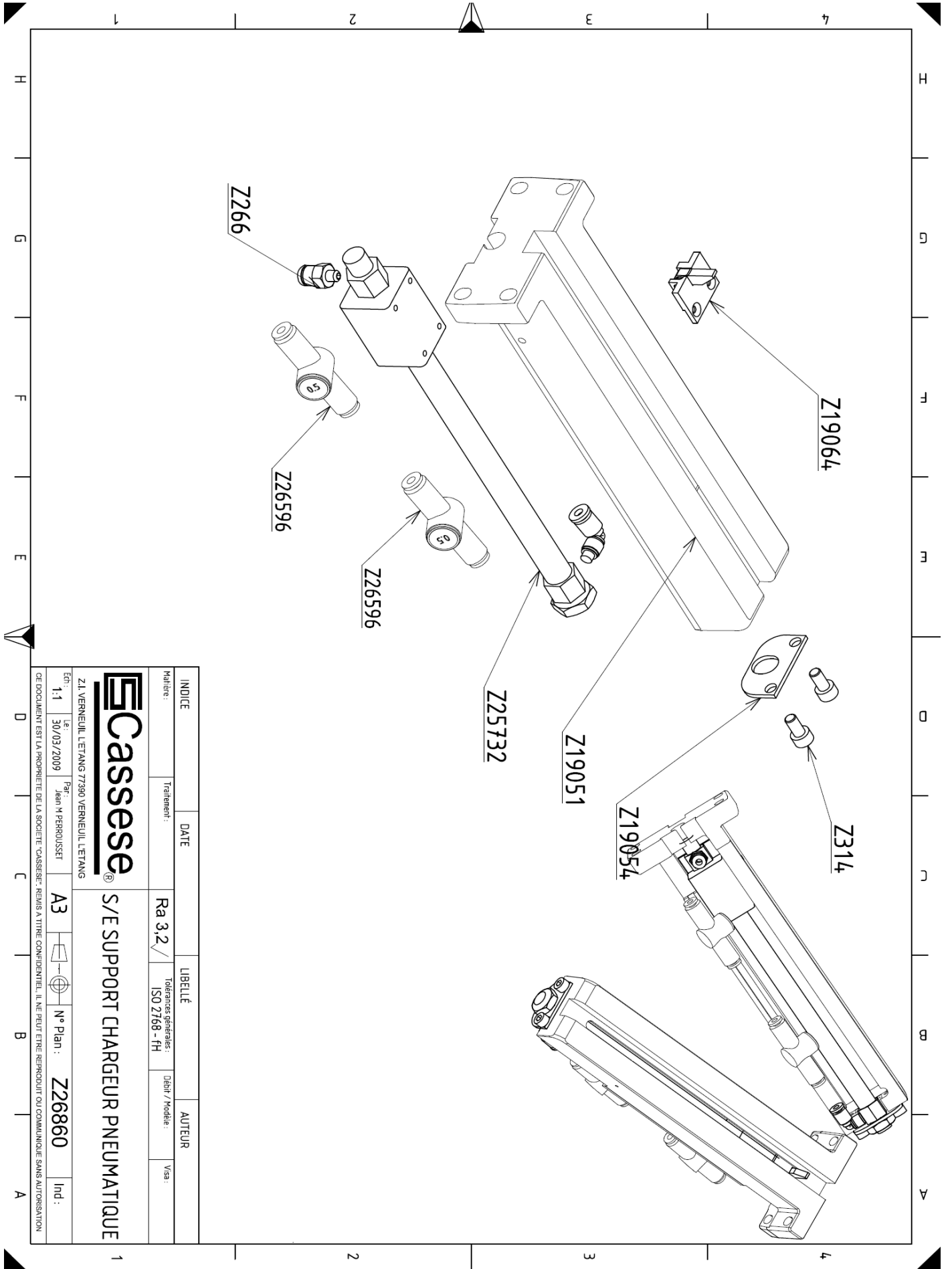

INDICE	DATE	LIBELLÉ	AUTEUR
Matière:	Traitement:	Tolérances générales: ISO Z768 - TH	Débit / Modèle:
Ra 3,2		Visa:	
Z1. VERNEUIL, LETANG 77390, VERNEUIL, LETANG		S/E SUPPORT CHARGEUR PNEUMATIQUE	
Ech: 1.1		N° Plan: Z26860	
Le: 30/03/2009		Ind:	
Par: Jean M PERRUSSET		A3	

CE DOCUMENT EST LA PROPRIÉTÉ DE LA SOCIÉTÉ CASSESE. REVIS A TITRE CONFIDENTIEL. IL NE PEUT ÊTRE REPRODUIT OU COMMUNIQUÉ SANS AUTORISATION

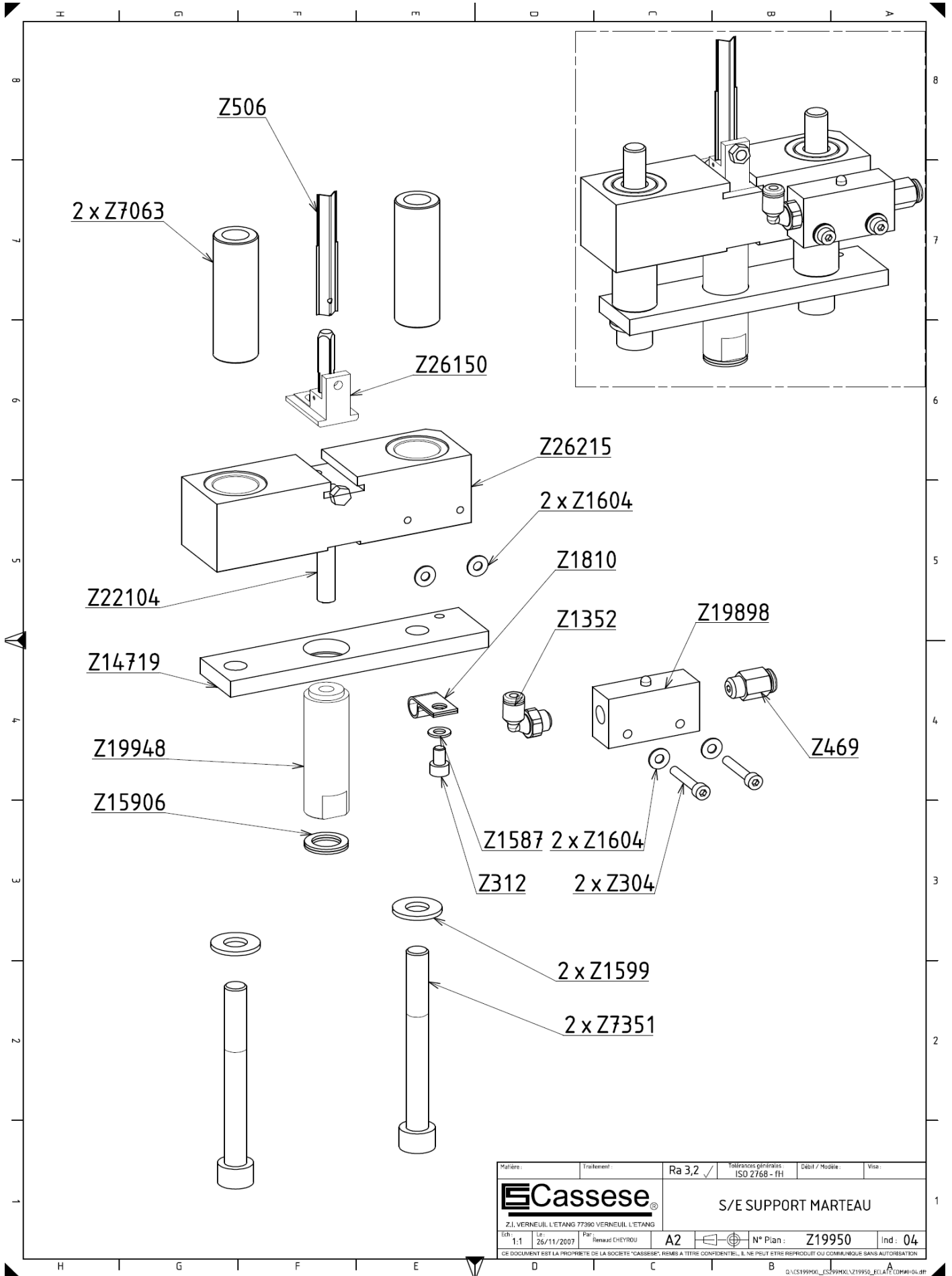

Matière:	Traitement:	Ra 3,2 ✓	Tolérances générales: ISO 2768 - FH	Débit / Modèle:	Visa:
		S/E SUPPORT MARTEAU			
Z.I. VERNEUIL L'ETANG 77390 VERNEUIL L'ETANG					
Ech: 1:1	Le: 26/11/2007	Par: Renaud CHEYBROU	A2	N° Plan: Z19950	Ind: 04
CE DOCUMENT EST LA PROPRIÉTÉ DE LA SOCIÉTÉ "CASSESE". REMIS A TITRE CONFIDENTIEL. IL NE PEUT ÊTRE REPRODUIT OU COMMUNIQUÉ SANS AUTORISATION					

D:\CS199MX\CS199MX\Z19950_ECLAÉ.COMM-04.dft

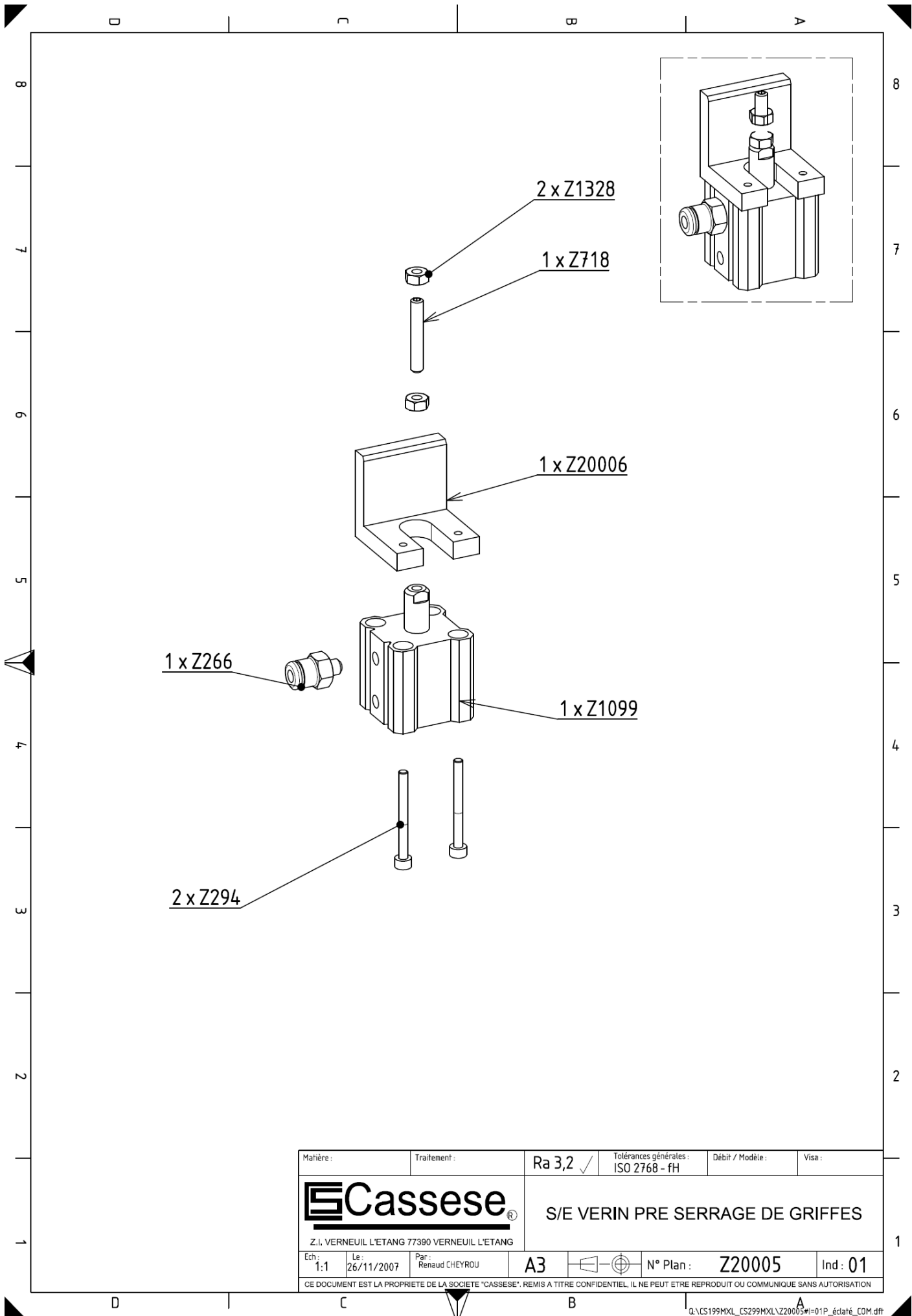

Matière :	Traitement :	Ra 3,2 ✓	Tolérances générales : ISO 2768 - fH	Débit / Modèle :	Visa :
Cassese ®		S/E VERIN PRE SERRAGE DE GRIFFES			
Z.I. VERNEUIL L'ETANG 77390 VERNEUIL L'ETANG					
Ech: 1:1	Le: 26/11/2007	Par: Renaud CHEYROU	A3	N° Plan : Z20005	Ind : 01
CE DOCUMENT EST LA PROPRIETE DE LA SOCIETE "CASSESE". REMIS A TITRE CONFIDENTIEL, IL NE PEUT ETRE REPRODUIT OU COMMUNIQUE SANS AUTORISATION					

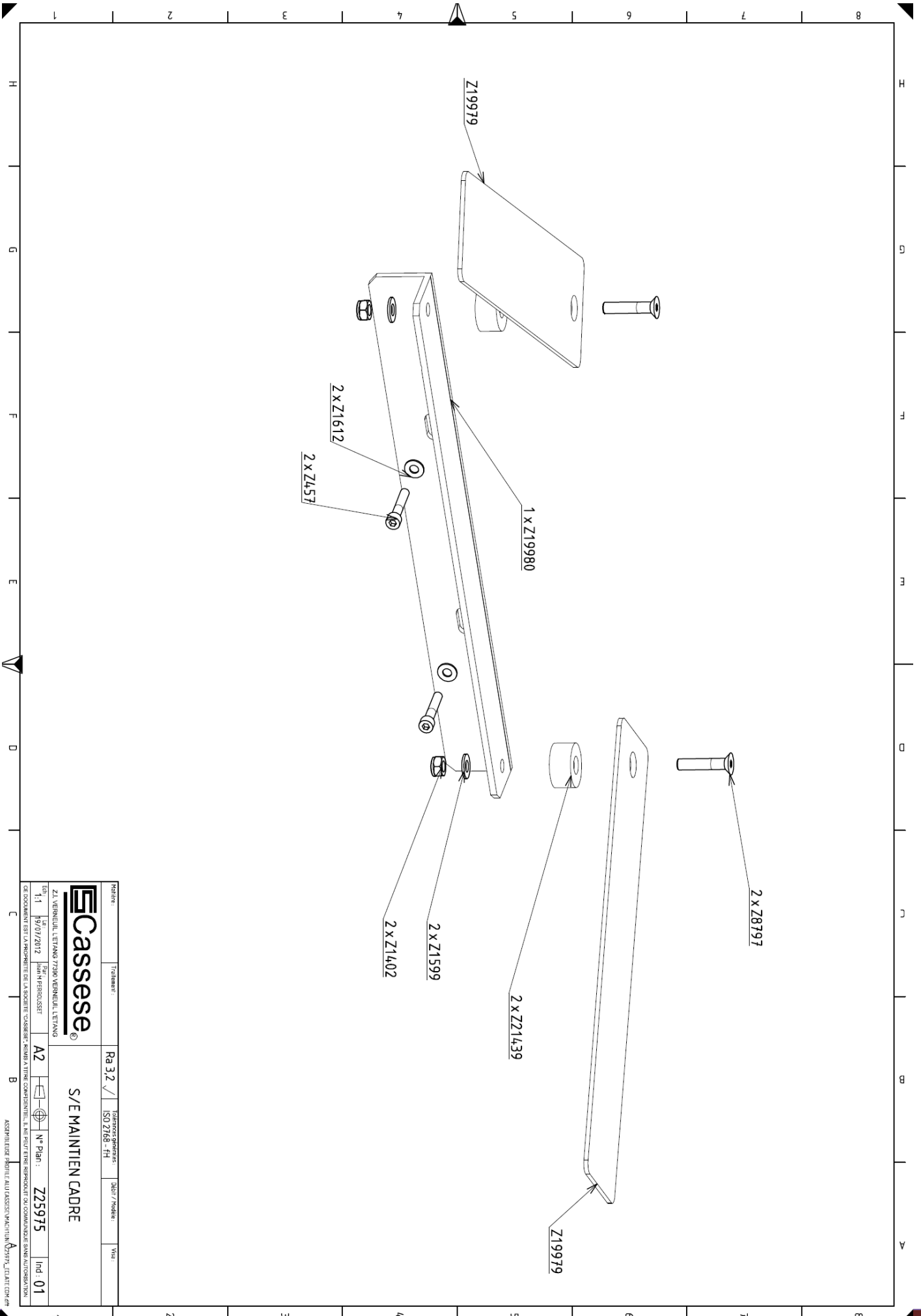

Part:	Reference:	Ra 3.2	Tolerance:	ISO 2768 - FH	3rd / 4th:	Mod:
Cassese®						
S/E MAINTIEN CADRE						
Ed:	1.1	19/07/2012	3rd:	SAH N FERROUSSET	A2	N° Part: Z25975
<small>CE DOCUMENT EST LA PROPRIETE DE LA SOCIETE CASSESE. NE PAS A TRE COMMERCEL. IL NE PEUT ETRE REPRODUIT OU COMMUNIQUE SANS AUTORISATION.</small>						Ind: 01

ASSEMBLESE PRINTE ALI CASSESE MACHIN. 025975_01.ETAT 01 04

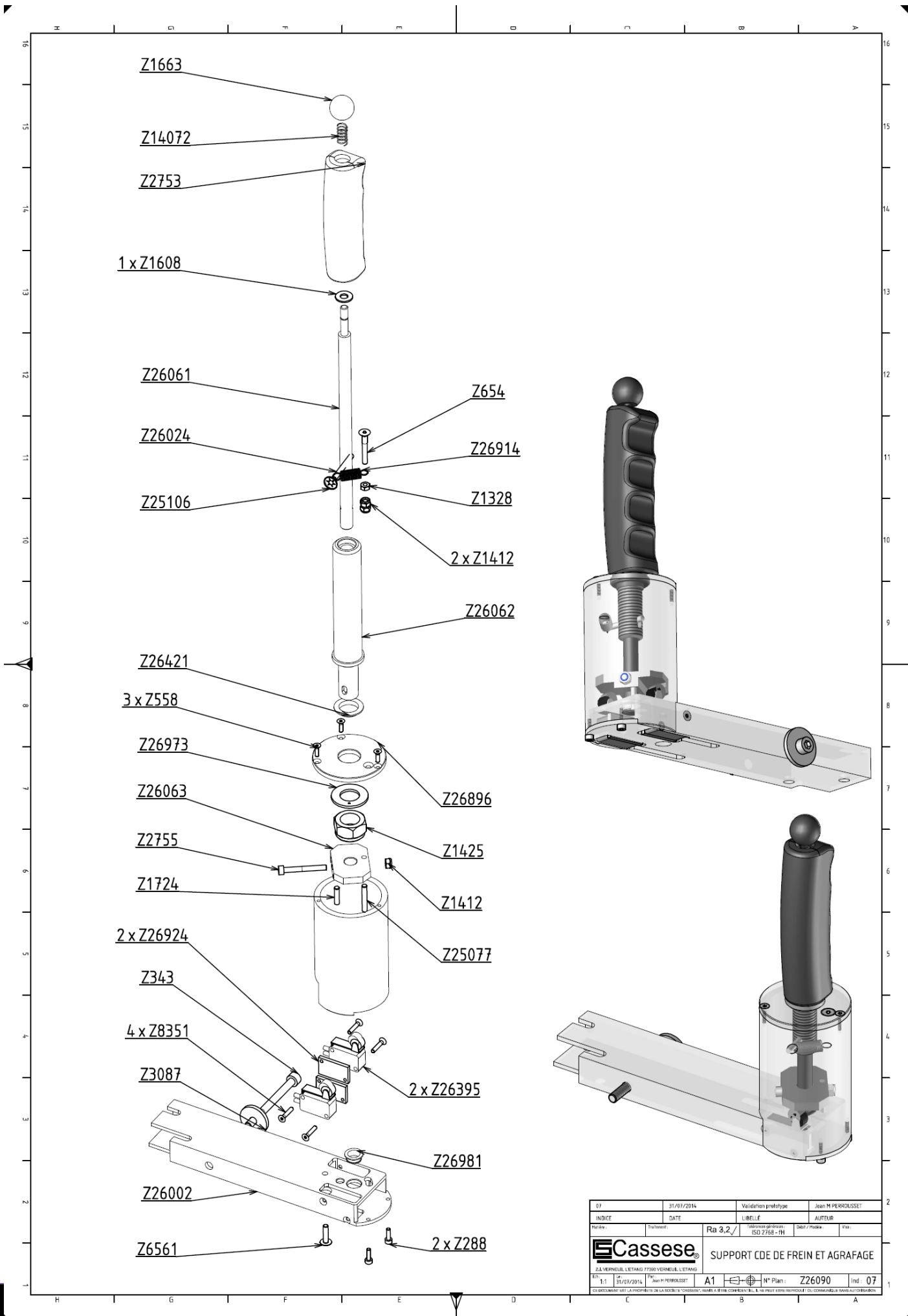

07	31/07/2014	Validation graphique	Jean M PERROUSSET
INDICE	DATE	LIBELLE	AUTEUR
Revisé :	Traitement :	Ra 3,2/	ISO 2768 - M
		SUPPORT CDE DE FREIN ET AGRAFAGE	
ZLL VERNEUIL L'ETANG 77500 VERNEUIL L'ETANG ETS : 31/07/2014 Jean M PERROUSSET		A1	N° Plan : Z26090 Ind : 07
CE DOCUMENT EST LA PROPRIÉTÉ DE LA SOCIÉTÉ "CASSESE" (SARL) À RTM COMBEAUX B. IL NE PEUT ÊTRE REPRODUIT NI COMMUNIQUÉ SANS AUTORISATION.			

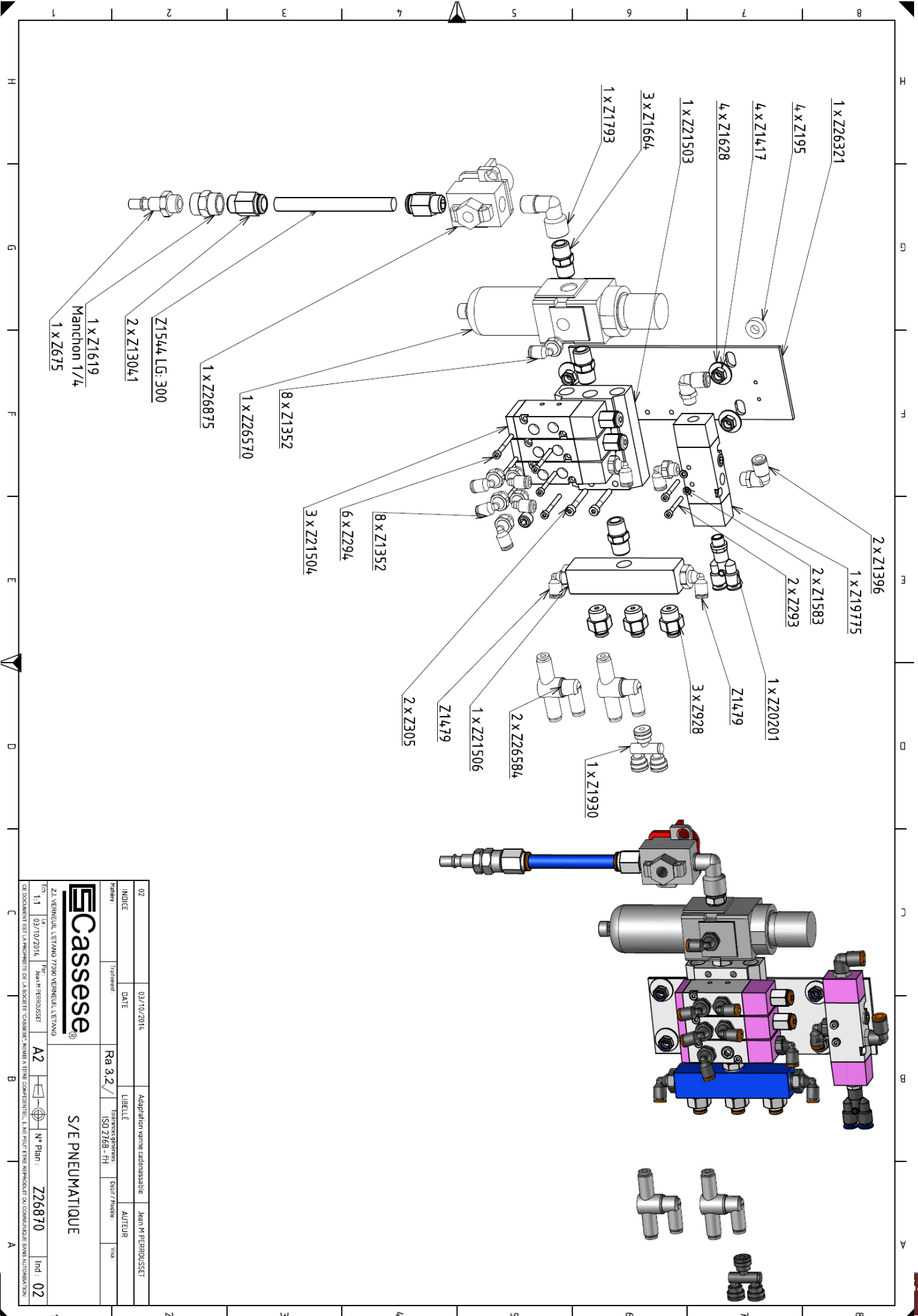

IV. SPARE PARTS LIST / NOMENCLATURE

REFERENCE	QTY/unit	DESIGNATION	DESCRIPTION
CS200CART	1 U	ASSEMBLEUSE CS200 AGRAFES CHARGEUR	CS200CART Pneumatic Underpinner
Z11183	2 U	VIS HC 6 X 30	SCREW HC 6 X 30
Z13376	2 U	AMORTISSEUR BUTEE	AMORTIZER STOP
Z1382	1 U	ECROU HM M 12	NUT FLAT D.12
Z1417	1 U	ECROU NYLSTOP M6	NUT NYLSTOP 6
Z1522	2 U	BOUTON ETOILE M6F	STAR BUTTON M 6 F
Z15710	3 U	VIS BHC A EMBASE ULF 6 X 10	BUTTON HEAD SCREW ULF 6 X 10
Z1583	2 U	RONDELLE Z3	WASHER Z3
Z1588	4 U	RONDELLE Z6	WASHER Z6
Z1606	1 U	RONDELLE M5	WASHER
Z1608	5 U	RONDELLE M6	WASHER M 6
Z1784	1 U	EMBASE ADHESIVE	ADHESIVE BASE
Z1847	1,00 m	GAINÉ SPIRALEE (M)	SPIRALE SHEATH
Z19950	1 U	S/E SUPPORT MARTEAU	HAMMER SUPPORT ASSY
Z12560	2 U	PALIER LISSE D: 20 D: 28 L:30	PLASTIC BEARING SLEAVES
Z12589	1 U	VIS HC 8 X 25	SCREW HEADSET M8X25
Z1394	1 U	POUSOIR A TETON (mini cde 5 pcs)	Wedge driver blade retaining screw (mini order 5 pcs)
Z14719	1 U	BUTOIR D'AGRAFAGE	STOP BAR
Z1599	2 U	RONDELLE M10	WASHER M D: 10
Z1604	2 U	RONDELLE M4	WASHER M 4
Z1606	1 U	RONDELLE M5	WASHER
Z1810	1 U	SERRE CABLE CV-8 D. 8	CLAMPING RING D.8
Z19948	1 U	AXE DE SUPPORT MARTEAU	HAMMER SUPPORT AXIS
Z2497	1 U	VIS BHC 6 X 10	SCREW BHC 6 X 10
Z26150	1 U	S/E SUPPORT MARTEAU ET POUSSOIR ASSEMBLE	HAMMER SUPPORT ASSY
Z26204	1 U	BARREAU INFERIEUR	BOTTOM BAR
Z303	2 U	VIS CHC M4-20 - 8.8	SCREW CHC 4 X 20
Z312	1 U	VIS CHC 5 X 8	SOCKET CAP SCREW M5 X 8
Z506	1 U	MARTEAU COURT (mini cde 5 pcs)	Short wedge driver blade (MOQ 5 pcs)
Z7063	2 U	COLONNE D: 20 LG: 61	COLUMN D: 20 L: 61
Z7351	2 U	VIS CHC 10 X 90	SCREW CHC 10 x 90
Z21604	1 U	S/E VERIN FREIN DE TABLE EQUIPE+RACCORD	SUB ASSY TABLE LOCKING PISTON+CONNECTOR
Z1314	1 U	COUDE 4 M5	ELBOW 4 M 5
Z1608	2 U	RONDELLE M6	WASHER M 6
Z1671	2 U	RONDELLE GROWER D: 6	WASHER GROWER D: 6
Z21338	1 U	VERIN SIMPLE EFFET D.20 C. 5 (VOIR COMMENTAIRE)	PISTON SINGLE ACTION D.20 C. 5 (SEE COMMENTS)
Z21661	1 U	SUPPORT RONDELLE ELASTOMERE	RUBBER WASHER SUPPORT
Z26371	1 U	GUIDE SUPPORT RONDELLE ELASTOMERE	GUIDE
Z330	2 U	VIS CHC M6-12 - 8.8	SCREW CHC 6 X 12
Z333	2 U	VIS CHC M6-20 - 12.9	SCREW CHC 6 X 20
Z658	1 U	VIS FHC 5 X 12	SCREW FHC 5 X 12
Z802	1 U	ENTRETOISE ELASTOMERE 90 17.8 X EP: 4	BUNG WASHER
Z22368	1 U	CAME CAPTEUR AGRAFAGE	WEDGE SENSOR FENCE
Z25272	1 U	EMBOUT DE PROFIL Z25192 790812 45 x 45°	PROFILE END Z25192 790812 45 X 45°
Z25975	1 U	S/E MAINTIEN CADRE	FRAME SUPPORT ARMS
Z1399	2 U	ENTRETOISE ACIER D: 8.4 X D: 21 X EP: 4	WASHER D.8.4 x D.21 x 4
Z1402	2 U	ECROU NYLSTOP M 10	NUT NYLSTOP 10
Z1599	2 U	RONDELLE M10	WASHER M D: 10
Z19979	2 U	PLAQUE SUPPORT CADRE	FRAME SUPPORT PLATE
Z19980	1 U	EQUERRE SUPPORT CADRE	SUPPORT
Z21439	2 U	RONDELLE PLASTIQUE D 40 X 8.2 EP 21.5	PLASTIC SPACER D 40 X 8.2 EP 21.5
Z28927	2 U	RONDELLE ALU D 30 X 8.5 EP 21.5	SPACER D 30 X 8.5 EP 21.5

REFERENCE	QTY/unit	DESIGNATION	DESCRIPTION
Z460	2 U	VIS CHC 8 X 70	SCREW CHC 8 X 70
Z8797	2 U	VIS FHC 10 X 50	SCREW FHC 10 x 50
Z26000	1 U	BATI	FRAME
Z26000EB1	1 U	BATI EBAUCHE	FRAME (DRAFT)
Z26039	2 U	BUTEE (VOIR COMMENTAIRES)	STOP
Z26090	1 U	S/E CDE DE FREIN ET AGRAFAGE	SUB ASSSY BRAKE AND STAPLING COMMAND
Z1328	1 U	ECROU H M 4	NUT
Z14072	1 U	RESSORT COMP D: 0,7 DE: 8.3 LO: 27 7,5 SP	SPRING COMP D: 0.7 DE: 8.3 LO: 27 7,5 SP
Z1412	2 U	ECROU NYLSTOP M4	NUT NYLSTOP M4
Z1425	1 U	ECROU NYLSTOP M 16	NUT NYLSTOP M16
Z1608	1 U	RONDELLE M6	WASHER M 6
Z1663	1 U	BOULE Ø 20 M6 F	BALL D.20 M6F
Z1724	1 U	GOUPILLE CYL 4 X 16 DIN 6325	CYLINDRICAL PIN 4 X 16
Z25077	1 U	GOUPILLE CYL 4 X 24 DIN 6325	CYLINDRICAL PIN 4 X 24
Z25106	1 U	ANNEAU GRIFAXE D: 4	LOCKING RING D: 4
Z26002	1 U	SUPPORT COMMANDE DE FREIN ET D' AGRAFAGE	SUPPORT
Z26024	1 U	GOUPILLE CYL 4 X 35 DIN 6325	CYLINDRICAL PIN 4 X 35
Z26061	1 U	TIGE DE DECLENCHEMENT	TRIGGER ROD
Z26062	1 U	SUPPORT POIGNEE	HANDLE SUPPORT
Z26063	1 U	BUTEE	STOP
Z26395	2 U	DISTRIBUTEUR 2/2 A GALET	DISTRIBUTOR
Z26421	1 U	BAGUE EPAULEE IGLIDUR GFM 16 18 04	BUSHING
Z26895	1 U	SUPPORT	TRIGGER ROD
Z26896	1 U	COUVERCLE	TRIGGER ROD
Z26914	1 U	RESSORT TRAC D: 0,7 DE: 8 LO: 21.40 8,7 SP (Voir commentaire)	SPRING TRAC D: 0,7 DE: 8 LO: 21.40 8,7 SP
Z26924	2 U	PLAQUETTE FIXATION	SUPPORT PLATE
Z26973	1 U	G GTM - 1630 - 1.5 Z26973	BUSHING
Z26981	1 U	PALIER CLIPS IGLIDUR MCM 10 02	BUSHING
Z2753	1 U	POIGNEE CAOUTCHOUC	HANDLE
Z288	2 U	VIS CHC 3 X 10	SOCKET CAP SCREW M3 X 10
Z305	1 U	VIS CHC M4-30 - 8.8	SCREW CHC 4 X 30
Z3087	1 U	ENTRETOISE ACIER D: 6.2 X D: 25 X EP: 3	WASHER
Z343	1 U	VIS CHC 6 X 70	SCREW CHC 6 X 70
Z558	3 U	VIS FHC 3 X 10	SCREW FHC 3 X 10
Z654	1 U	VIS FHC M4-30 - 8.8 TOTALEMENT FILETEE	SCREW FHC 4 X 30
Z6561	1 U	VIS BHC A EMBASE ULF 4 X 16	VIS BHC A EMBASE ULF 4 X 16
Z732	1 U	VIS HC 6 X 6	SCREW HC 6 X 6
Z8351	4 U	VIS FHC 3 X 16	SCREW FHC 3 x 16
Z26589	1 U	PEDALE 3/2 AVEC CAPOT	PEDAL FOR CS199/299MXL2/200 (NOT SUITABLE FOR OTHER MACHINES)
Z26589EB1	1 U	PEDALE 3/2 AVEC CAPOT SANS RACCORD	PEDAL
Z26809	1 U	DOIGT D' INDEXAGE	LOCATING PIN
Z1478	1 U	BOUTON ETOILE F: M 4	STAR BUTTON M 4 F
Z26953	1 U	AXE	AXIS
Z26954	1 U	CORPS	BODY
Z26957	1 U	RESSORT COMP	COMPRESSION SPRING
Z26870	1 U	S/E PNEUMATIQUE	PNEUMATIC ASSY
Z1035	1 U	REPERE DE CABLE 0	CABLE MARK 0
Z1037	3 U	REPERE DE CABLE 1	MARK CABLE 1
Z1039	1 U	REPERE DE CABLE 2	CABLE MARK 2
Z1042	1 U	REPERE DE CABLE 3	CABLE MARK 3
Z1046	1 U	REPERE DE CABLE 4	CABLE MARK 4
Z1092	1 U	REPERE DE CABLE 9	CABLE MARK 9
Z11100	4,00 m	TUBE P.U 2,5 X 4 ROUGE (LE M)	PU ROLL TYPE 4 x 2.5 RED
Z13041	2 U	DROIT 10 1/4	STRAIGHT CONNECTOR 10 1/4
Z1343	4 U	ECROU H M8	NUT M8

REFERENCE	QTY/unit	DESIGNATION	DESCRIPTION
Z1352	11 U	COUDE 4 1/8 ORIENTABLE	ELBOW 4 1/8
Z1386	4 U	ECROU HM M8	NUT FLAT D. 8
Z1417	4 U	ECROU NYLSTOP M6	NUT NYLSTOP 6
Z1479	10 U	COUDE 4 1/4	ELBOW 4 1/4
Z15019	1 U	VOYANT PNEUMATIQUE	AIR PRESSURE INDICATOR
Z1536	7,00 m	TUBE P.U 2,5 X 4 BLEU (LE M)	PU ROLL TYPE 4 x 2.5 BLUE
Z1608	4 U	RONDELLE M6	WASHER M 6
Z1619	1 U	MANCHON F 1/4	COUPLING SLEEVE F 1/4
Z1664	3 U	MAMELON M 1/4 CON	NIPPLE 1/4
Z1690	1 U	REDUCTION M 1/4 M 1/8 CYL	REDUCTION M 1/4 M 1/8 CYL
Z1697	5,00 m	BITUBE PU 2,5 X 4 BLEU/NOIR (LE M)	TUBE PU 2,5 X 4 BLUE/BLACK (BY METER)
Z1793	1 U	COUDE M 1/4 CON F 1/4 CYL	ELBOW 1/4 MF
Z18403	1 U	MICROREGULATEUR	AIR REGULATOR
Z1849	2 U	BOUCHON 1/8 CONIQUE	CAP 1/8
Z1859	1 U	BOUCHON 6	CAP D.6
Z1930	2 U	Y FEMELLE 4	Y FEMALE 4
Z19766	4 U	UNION D 4	JUNCTION CONNECTOR D 4
Z19775	1 U	DISTRIBUTEUR 5/2 CDE PNEUMATIQUE 1/8 MINIATURE	5/2 AIR CONTROL VALVE 1/8
Z20015	1 U	COUDE 4 1/8 FEMELLE ORIENTABLE	ELBOW 4 1/8 F
Z20201	1 U	Y DE 4 M1/8 CYL	Y DE 4 M1/8 CYL
Z21503	1 U	EMBASE PNEUMATIQUE 3 POSTES EMC	MANIFOLD 100M3F
Z21504	3 U	DISTRIBUTEUR 5/2 RAPPEL RESSORT 1/8 EMC	DISTRIBUTOR PNEUMATIC1/8 5/2 SPRING
Z21506	1 U	BARRETTE DE DISTRIBUTION 3 SORTIES 1/4 G	DISTRIBUTOR
Z24071	1 U	FIN DE COURSE EMC 2/2 (VOIR COMMENTAIRES)	END OF RUN CONTACT 2/2 (SEE COMMENTS)
Z26001	1 U	PANNEAU AMOVIBLE	REMOVABLE PANEL
Z261	1 U	REDUCTION M 6 F 4	REDUCTOR M 6 F 4
Z26321	1 U	SUPPORT PNEUMATIQUES	PNEUMATIC SUPPORT
Z26395	1 U	DISTRIBUTEUR 2/2 A GALET	DISTRIBUTOR
Z26570	1 U	FILTRE REGULATEUR 1/4 AW20-F02	AIR CONDITIONNER
Z26575	2 U	S/E DISTRIBUTEUR 5/2 +BOUTON TOURNANT 2 POS	DISTRIBUTOR
Z26584	2 U	CELLULE VR1210F-04_2_03	PNEUMULTIC CELL
Z26596	2 U	LIMITEUR DE DEBIT FIXE Ø 0.5	FLOW REDUCER
Z26875	1 U	VANNE CADENASSABLE 1/4	VALVE 1/4
Z27016	1 U	PLANCHE D'ETIQUETTES CS200CART	BOARD OF LABELS CS200CART
Z27463	1 U	RONDELLE ALU D. 15.2 x 20 x Ep. 1.5	
Z293	2 U	VIS CHC 3 X 25	SCREW CHC 3 X 25
Z294	6 U	VIS CHC 3 X 30	SCREW CHC 3 X 30
Z305	2 U	VIS CHC M4-30 - 8.8	SCREW CHC 4 X 30
Z352	1 U	PURGE RAPIDE 1/8	QUICK EXHAUST VALVE 1/8
Z469	4 U	DROIT 4 1/8	MALE TUBE CONNECTOR 4 1/8
Z675	1 U	EMBOUT MALE RAPIDE M 1/4	1/4 MALE CONNECTION
Z928	3 U	DROIT 4 1/4	MALE TUBE CONNECTOR 4 1/4
Z947	1 U	MANOMETRE + ETRIER M. 1/8	MANOMETER M 1/8 + STIRRUP
Z27045	1 U	S/E EMBALLAGE CS200CART	PACKING SUB ASSY
Z12064	1 U	PALETTE CS55M-CS199MXL-CS299MXL2-CS4008XL-MF10-MF20-MF40.	PALET FOR CS55M-CS199MXL-CS299MXL2-CS4008XL-MF10-MF20-MF40.
Z19332	1 U	EMBALLAGE 700 X 655 X 1250 INTER. CLOCHE+COUVERCLE	CRATE EXPAK OSB 700 x 655 x 1050
Z26918	1 U	ETIQUETTE SECURITE LIRE LE MANUEL	SAFETY LABEL
Z27038	1 U	S/E BOITE ACCESSOIRES CS200CART	ACCESSORY BOX ASSY
Z27039	1 U	MANUEL TECHNIQUE ET D'UTILIS. CS200CART	MANUEL TECHNIQUE ET D'UTILIS. CS200CART
Z2798	1,00 m	PAPIER ANTIROUILLE (LE KG) VOIR COMMENTAIRES	RUST PROTECTION PAPER
Z9162	1 U	PLANCHE D'ETIQUETTES ASSEMBLEUSES	PLANCHE D'ETIQUETTES ASSEMBLEUSES
30307NCOI	1 U	BTE 6 CHARGEURS COINS N° 7	BOX 6 CARTRIDGES #7
30310NCOI	1 U	BTE 6 CHARGEURS COINS N°10	BOX 6 CARTRIDGES #10
31310BDCCO	1 U	BTE 6 CHARGEURS COINS N°10 BD	BOX 6 CARTRIDGES #10 HW
Z28453	1 U	TOLE RECOUVREMENT GUIDAGE TABLE	

REFERENCE	QTY/unit	DESIGNATION	DESCRIPTION
Z28525	1 U	ENSEMBLE MECANIQUE CS200CART & MACHCART	
Z12062	2 U	ENTRETOISE ACIER D: 10.1 X D: 25 X EP: 3	IRON SPACER D: 10.1 x D: 25 x EP: 3
Z1270	4 U	VIS HC M6-8 POINTEAU - 8.8	SCREW HC 6 X 8 POINTEAU
Z12724	3 U	DOUILLE A BILLES DOUBLE SM 20 X 32 X 80	BUSHING 20 X 32 X 80
Z13331	2 U	DOUILLE A BILLES SM 30 X 45 X 64 G UU	LINEAR BEARING 30 X 45 X 64
Z1587	5 U	RONDELLE Z D5	WASHER Z D5
Z1588	8 U	RONDELLE Z6	WASHER Z6
Z16028	1 U	BUTEE ELASTIQUE D: 15 X 10 M5 POLYURETHANE GRIS	RUBBER END FOR TOP CLAMPS (order mini 2pcs)
Z1606	1 U	RONDELLE M5	WASHER
Z1728	2 U	GOUPILLE CYL 5 X 12 DIN 6325	CYLINDRICAL PIN 5 X 12
Z18374	1 U	BARREAU AV FONDERIE USINE	ALUMINUM CAST BLOCK
Z18450	1 U	S/E BARREAU DE GRIFFES ESCAMOTABLES Ø 40 (VOIR COMMENTAIRES)	CLAMPING PISTON ASSEMBLY (SEE COMMENTS)
Z18451	1 U	SUPPORT VERIN DE SERRAGE	CLAMPING PISTON SUPPORT
Z19240	1 U	VERIN D.80 C.100 RALLONGE +11 MM (VOIR COMMENTAIRE)	CYLINDER D.80 C.100
Z20005	1 U	S/E VERIN PRE SERRAGE DE GRIFFES	SUB ASSY PRE CLAMPING PISTON
Z22355	1 U	ANNEAU D'ARRET A ARCBOUTEMENT Ø 8	LOCKING WASHER
Z23351	1 U	PORTE BAGUE D' ETANCHEITE	SEALING PROTECTION
Z23440	1 U	S/E BUTEE AGRAFAGE	SUB ASSY
Z24156	2 U	VIS CHC 8 X 45 TETE BASSE ZINGUEE 10.9	SCREW CHC 8 X 45
Z25988	1 U	BARREAU AR USINE	CAST COLUMN SUPPORT
Z26724	1 U	BARREAU D'AGRAFAGE FONDERIE USINE MACH4CART	MACHINED DISTRIBUTOR SUPPORTING BAR FOR SQUARE HAMMER
Z26860	1 U	S/E SUPPORT CHARGEUR PNEUMATIQUE CART	PNEUMATIC CARTRIDGE SUPPORT ASSY
Z26864	1 U	CAME DE DETECTION	DETECTION CAM
Z26980	1 U	S/E COLONNE + SUPPORTS VERIN ET PRESSEUR	COLUMN SUB ASSY
Z27175	1 U	S/E GRIFFES	CLAMP ASSY
Z28448	1 U	COLONNE D: 20 LG: 335	SHAFT D: 20 LG: 335
Z28450	1 U	MANCHON DE GUIDAGE	
Z28452	1 U	TABLE USINE	
Z28459	2 U	PALIER AXE GUIDAGE TABLE	
Z28800	1 U	S/E TABLE BUTEES 2018	
Z316	2 U	VIS CHC M5-16 - 8.8	SCREW CHC 5 X 16
Z317	1 U	VIS CHC M5-20 - 8.8	SOCKET CAP SCREW M5 X 20
Z320	2 U	VIS CHC M5-35 - 8.8	SCREW CHC 5 X 35
Z331	8 U	VIS CHC M6-16 - 8.8	SOCKET CAP SCREW M6 X 16
Z337	2 U	VIS CHC M6-35 - 8.8	SCREW CHC 6 X 35
Z3645	1 U	VIS HC 6 X 6 POINTEAU	SCREW HC 6 X 6 POINT END
Z4460	2 U	VIS HC 4 X 6 POINTEAU	SCREW HC 4 X 6 POINT END
Z5849	2 U	COLONNE D: 20 LG: 414	SHAFT D: 20 LG: 414
Z5850	3 U	VIS CHC 10 X 16 TETE BASSE	SCREW CHC 10 X 16 FLAT HEAD
Z6610	2 U	VIS CHC 8 X 16 TETE BASSE ZINGUEE	SCREW CHC 8 X 16 FLAT HEAD
Z817	1 U	S/E AGRAFAGE ET GUIDE (mini cde 2 pcs)	Wedge distributor block (mini order 2 pcs)
Z863	1 U	BILLE D.8	BALL D.8
Z8761	1 U	BAGUE D'ETANCHEITE SD 30 X 40 X 4	AIRTIGHT RING SD 30x40x4
Z97	1 U	VIS POINTEAU	SCREW POINT END
Z290	2 U	VIS CHC M3-16 - 8.8	SCREW CHC 3 X 16
Z332	1 U	VIS CHC M6-18 - 8.8	SCREW CHC 6 X 18
Z333	2 U	VIS CHC M6-20 - 12.9	SCREW CHC 6 X 20
Z482	2 U	VIS CHC 4 X 12 TETE BASSE	SCREW CHC 4 X 12 FLAT HEAD
Z6324	1 U	ECROU CARRE A LANGUETTE M 6	SQUARE NUT WITH SPRING PLATE M 6
Z868	2 U	VIS H 6 X 14	SCREW H 6 X 14
Z879	4 U	VIS H 8 X 40	SCREW H 8 X 40
Z8800	8 U	RONDELLE LL8	WASHER LL D: 8
Z949	1 U	VIS TETE CARREE SPE. 6 X 20 (VOIR COMMENTAIRE)	SCREW SQUARE HEAD SPE. 6 x 20
Z869	1 U	VIS H 6 X 20	SCREW H 6 X 20
Z9596	1 U	COLLIER COLSON 4.6 X 200 NOIR	TIE RAP COLSON 4.6 x 200 NOIR

V. PNEUMATIC SCHEMATIC / SCHEMA PNEUMATIQUE

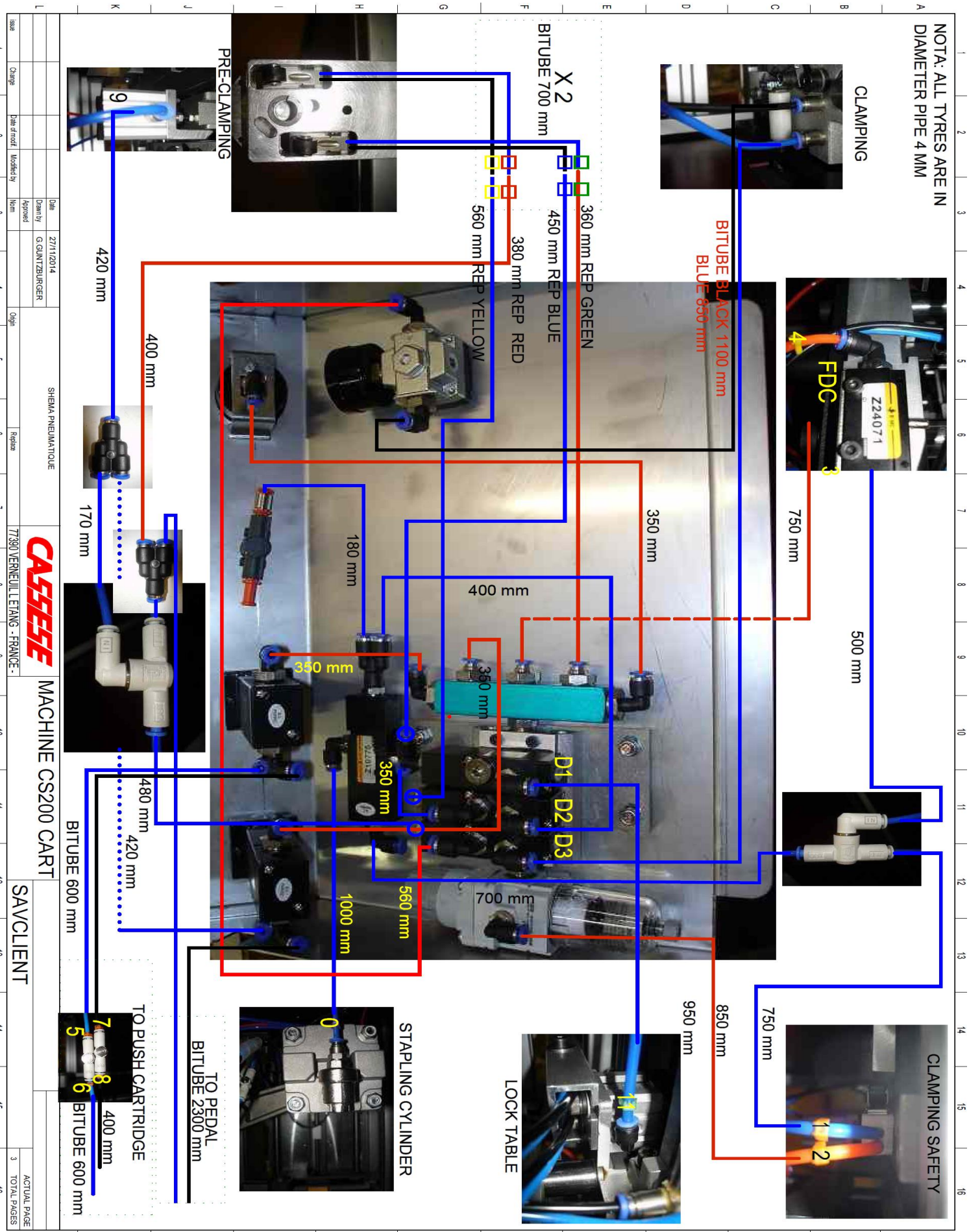

Issue	Change	Date of modif.	Made by	Date	Drawn by	Approved	Origin	Release
				27/11/2014	G. GUNTZBURGER			

SHEMA PNEUMATIQUE

CASSESE

77390 VERNEUIL L'ETANG - FRANCE

MACHINE CS200 CART

SAVCLIENT

ACTUAL PAGE 3 / TOTAL PAGES 16

VI. CE CERTIFICATE / DECLARATION DE CONFORMITE

DECLARATION < CE > DE CONFORMITE

Le fabricant soussigné:

CASSESE SARL - 8 rue Denis Papin - zone industrielle

77390 Verneuil l' étang

France.

Déclare que la machine neuve désignée ci-après, est conforme:

- aux dispositions réglementaires définies par l'annexe 1 de la directive européenne:

" 2006/42/CE ".

- aux directives: "Equipements base tension " 2006/95/CE " Compatibilité électromagnétique:

" 2006/108/CE".

ASSEMBLEUSE D'AGRAFES :

.. pneumatique.

CS200CART : N° de série:

Fait à Verneuil l' Etang

Le: 01/09/2014

Le Gérant :

Z26838

